



Adaptive Switching Hybrid Blast-STBC MIMO System

Mohammed Salemdeeb^{1*} and Ammar Abu-Hudrouss²

¹Department of Electrical-Electronics Engineering, Bartin University, Turkey.

²Department of Electrical Engineering, Islamic University of Gaza, Palestine.

Authors' contributions

This work was carried out in collaboration between both authors. Author MS designed the study, performed the analysis, wrote the codes for simulation, and wrote the first draft of the manuscript. Author AAH managed the analyses of the study and managed the literature searches. Both authors read and approved the final manuscript.

Article Information

DOI: 10.9734/JERR/2021/v20i1017396

Editor(s):

(1) Dr. P. Elangovan, SRM TRP Engineering College, India.

Reviewers:

(1) Matteo Bruno Lodi, University of Cagliari, Italy.

(2) Ari Endang Jayati, Universitas Semarang, Indonesia.

Complete Peer review History: <https://www.sdiarticle4.com/review-history/70983>

Original Research Article

Received 14 May 2021

Accepted 19 July 2021

Published 27 July 2021

ABSTRACT

Fading in a wireless channel has negative effects on the performance of communication systems. Bell Laboratories layered space-time (BLAST) has been used to get a high data rate while space-time block codes (STBC) have been used to get a low bit error rate (BER) performance. Under deep faded channels, hybrid BLAST-STBC systems are considered as a trade-off between BLAST and STBC systems. By exploiting the benefits of both systems, a new method to represent a 4×4 multiple-input and multiple-output (MIMO) system is proposed and studied, in which the transmission process is carried out adaptively between both 4×4 VBLAST, Quasi-Orthogonal STBC (QOSTBC) and Hybrid systems according to the transmit links state. The proposed adaptive switching hybrid system (ASHS) reduces the total transmitted power, achieves the maximum throughput by obtaining the best BER. An adaptive switching transmission scheme using the strategy of measuring the transmit links fading is investigated as well. The simulated results are obtained in an environment of a 4×4 MIMO system using MATLAB platform where the total transmitting power is normalized to unity. The detections are done using the maximum likelihood (ML) receiver. The proposed ASHS system shows a lot of advantages such as maximum throughput is obtained in bad channel states, no additional transmit power is needed and no additional bandwidth is needed. Finally, under deep fading condition, the proposed ASHS transmission scheme obtains the best BER, reduces wasting the total transmitted power, achieves the maximum throughput and obtains the best BER.

*Corresponding author: Email: msalemdeeb@bartin.edu.tr;

Keywords: MIMO; BLAST; STBC; hybrid BLAST-STBC; hybrid MIMO transmission schemes.

1. INTRODUCTION

Vertical BLAST (VBLAST) MIMO system performs spatial multiplexing technique that can provide a high data rate transmission [1,2]. Several MIMO techniques have been introduced to achieve diversity gain, such as STBC [3], and to achieve capacity gain, such as spatial multiplexing [4].

In the last decades, there are several approaches to combine STBC and BLAST systems to obtain both spatial multiplexing gain and transmit diversity together in one system [5]. This idea emerged in multi-user systems, when each user uses an STBC encoder then all users may be considered as a single user having Multilayer STBC (MU-STBC) communication scheme, as a result, this user gains diversity benefits and high spectral efficiency. As a result, the symbol detection approaches used for MU-STBC systems can be applied to the case of the hybrid system [6]. Involving STBC encoders in BLAST systems is called hybrid STBC-BLAST system [7], Hybrid MIMO Transmission Schemes (HMTS) [8], combined STBC and BLAST or combined STBC and SM system [9], hybrid BLAST-STBC [10], combined array processing and STBC [11] and in some references it is referred to as multi-layered STBC (MLSTBC) system [11]. MLSTBC architecture was first implemented with space-time trellis codes in ref. [10]. The main idea here is to use one couple or more of BLAST layers as one STBC encoder. Low-complexity detection for MLSTBC was introduced in ref. [12].

Throughput is a fundamental measure of the wireless data link quality. It is defined as the number of correctly received information bits per second and this is required to be as high as possible [13].

Fading is a wireless channel impairment [13]. Basically, wireless communications take place in public areas where the transmission of wireless signals suffers from many problems such as fading, shadowing and path loss, etc. Accordingly, the wireless channel changes with time and frequency affecting the total channel capacity, and since the channel-state is frequently changing so the quality of the received signal is unpredictable [14]. Positively, some transmission techniques like adaptive transmission schemes play a vital role in

enhancing the throughput. On fading channels, the standards for the next generation of wireless systems are developed to achieve high spectrum efficiency, this development is based on one of the key enabling transmission techniques which is the adaptive transmission [15–17]. In ref. [18], a mathematical framework is proposed to maximize the user throughput using various parameters such the packet length, the constellation size and the symbol rate as optimization variables.

In high data-rate next generation MIMO wireless communication systems, the common adaptive transmission schemes are antenna subset selection, adaptive modulation and transmit switching schemes [15]. In antenna selection every way of selection of transmit antennas has a base to select on, it may be based on signal-to-noise (SNR) threshold, BER threshold, bandwidth efficiency or channel norm threshold [16,17].

In ref. [18], a full study and comparison of the conventional 4x4 VBLAST system regarding the system capacity and BER performance using QPSK transmitting modulation and ML receiver are introduced. The transmit-link deep-fading effect on the effective SNR, BER and system capacity is also studied in a comparison with the conventional 1x4, 2x4, 3x4 and 4x4 VBLAST systems. The research [18] states that every possible transmit link deep fade case for SNR lower than -20 dB is equivalent to turn off that transmit link and approximately all the power of this link will be wasted. The SNR_{eff} and the system capacity of deeply faded one transmit-link is slightly decreased if this link is powered off. In contradiction, when one transmit-link is deeply faded, the 4x4 VBLAST system performance will be greatly affected comparing to normal conditions, but the effect becomes smaller when two transmit-links are deeply faded and so on. Those results lead to seek for a switching scheme that can make an improvement on the performance. In case of all transmit-links gain lower than -30 dB the system will be disappeared.

In ref. [19], a full analysis and comparison between 4x4, G_2+1+1 , G_2+G_2 and QOSTBC MIMO system were introduced regarding BER, capacity, and throughput; where G_2 is an Alamouti [3] STBC encoder. G_2+1+1 defined as a 4x4 MIMO system with two transmit antennas

that use Alamouti encoder and the other two antennas that use BLAST transmission schemes, and G_2+G_2 defined as a 4x4 MIMO system with two Alamouti encoders that each two transmit antennas use Alamouti encoder transmission schemes. In summary, the results of the comparison between the throughputs of those systems results that, the 4x4 VBLAST system achieves the best throughput when no deep fading is exist. Nevertheless, G_2+1+1 system gives the best throughput in scenario of one transmit-link deep fade. Also, G_2+G_2 system gives the best throughput results, if 2 or 3 transmit-link are deeply faded. Finally, when all of transmit-links are deeply faded QOSTBC system prove itself to be the optimal solution achieving very good throughput in this case. In ref. [20], the authors studied the relay assisted uplink Hybrid STBC-BLAST with QPSK, 16 QAM and 64 QAM modulation techniques to improve the relay's capacity of the second hop and it is mentioned as MLSTBC system as named in ref. [11]. Authors in ref. [21] proposed a low-complexity genetic algorithm to solve the joint antenna selection problem in Hybrid STBC-SM MIMO Systems by maximizing the channel capacity under some constraints. On the other hand, the researchers in ref. [22] worked on improving BER of hybrid STBC-BLAST using singular value decomposition (SVD) for the estimated wireless channel.

This paper proposes a new transmission scheme for wireless MIMO communication system named ASHS, the transmitter switches between BLAST, Hybrid BLAST and QOSTBC techniques, this selection depends on the received effective SNR measured on transmitted training sequence and aimed to track the maximum throughput (best capacity with best BER).

The rest of this paper is organized as follows, the second section gives some theoretical background on the MIMO system models. The third section explains in details the proposed ASHS system describing the switching process. The fourth section gives the simulation results and discussions. Finally, the fifth section summarizes the whole study.

2. MATERIALS MIMO COMMUNICATION SYSTEMS

2.1 MIMO System Model

Let a transmitted vector to be $\mathbf{x}=[x_1, x_2, x_3, \dots, x_M]^T$ and a MIMO channel matrix to be \mathbf{H} with N

(receive antennas) $\times M$ (transmit antennas) dimensions, whose element (fading gain) h_{ij} is a random Gaussian complex coefficient, with zero mean and unity variance, between the j^{th} transmit and i^{th} receive antennas. In the ideal case, when each path is considered statistically independent and in the presence of Additive White Gaussian Noise (AWGN) \mathbf{n} , the received signal vector $\mathbf{r}=[r_1, r_2, r_3, \dots, r_M]^T$ can be given as follows [1]:

$$\mathbf{r} = \mathbf{H}\mathbf{x} + \mathbf{n} \quad (1)$$

2.2 Capacity of MIMO Systems

On a flat fading channel, MIMO communication system capacity can be defined as [23],

$$C_{\text{MIMO}} = \left(\det \left(\mathbf{I}_N + \frac{\text{SNR}}{M} \mathbf{H}^H \mathbf{H} \right) \right) \text{ bps/Hz} \quad (2)$$

This theoretical MIMO system capacity expression indicates that the capacity increases linearly with the number of antennas [24]. The average received effective SNR of 4x4 MIMO system is computed as follows [25]:

$$\text{SNR}_{\text{eff}} = \frac{E_s \|\mathbf{H}\|_F^2}{MN_0} = \text{SNR} \|\mathbf{H}\|_F^2 \quad (3)$$

where the average received SNR of four receive antennas is SNR_{eff} , E_s is the energy of the transmitted symbol, N_0 is the noise spectral density and $\|\mathbf{H}\|_F^2$ is the squared value of Frobenius norm [26] of \mathbf{H} , which is equal to

$$\|\mathbf{H}\|_F = \sqrt{\sum_{j=1}^N \sum_{i=1}^M h_{ij}^2} \quad (4)$$

The individual contribution of each transmit or receive antenna to the effective SNR is through the contribution of $\|\mathbf{H}\|_F^2$ [27].

For a data rate R the throughput can be defined as [9],

$$T = R (1-\text{BER}) \quad (5)$$

The capacity of a wireless channel is C , but the data to be sent over this channel has a rate R where $R \leq C$.

2.3 Space-Time Block Coding (STBC)

Generally, STBC results a signal-reliability enhancement even if one or more path coefficients are in deep fading, there is still possibility to get an error-free signals.

2.3.1 Alamouti STBC

A simple STBC was suggested in ref. [3], Alamouti divided the transmitted symbols into two groups to be sent in two time slots. In the first time slot, the original signals x_1 and x_2 with half power are sent whereas in second time slot conjugate version of the signals $-x_2^*$ and x_1^* are sent with half power. The data rate is still the same (1 symbol per time slot).

For any quadrature modulated symbol x_i , the STBC transmitted code-word is \mathbf{x} , as in (6)

$$\mathbf{x} = \begin{pmatrix} x_1 & -x_2^* \\ x_2 & x_1^* \end{pmatrix} \quad (6)$$

Assuming a flat Rayleigh fading channel, the virtual channel matrix \mathbf{H}_A for a 2×2 MIMO system for two time slots using Alamouti scheme is

$$\mathbf{H}_A = \begin{pmatrix} h_{11} & h_{12} \\ h_{21} & h_{22} \\ h_{11}^* & -h_{12}^* \\ h_{21}^* & -h_{22}^* \end{pmatrix} \quad (7)$$

The rows of the matrix represent the time slots while the columns represent antennas. Therefore, to transmit k symbols in p time slots, the code rate is $R_s = k/p = 1$ Symbols/Time for Alamouti. The demodulation in the receiver treats the 2×2 channel matrix for two time slots as a virtual 4×2 matrix, resulting a received signal $\tilde{\mathbf{r}}$. The AWGN noise term is still white.

$$\begin{pmatrix} \tilde{r}_1 \\ \tilde{r}_2 \end{pmatrix} = \begin{pmatrix} h^2 & 0 \\ 0 & h^2 \end{pmatrix} \begin{pmatrix} x_1 \\ x_2 \end{pmatrix} + \begin{pmatrix} n_1 \\ n_2 \end{pmatrix} \quad (8)$$

$$h^2 = |h_{11}|^2 + |h_{12}|^2 + |h_{21}|^2 + |h_{22}|^2 \quad (9)$$

2.4 Quasi-Orthogonal STBC

In ref. [28], a new full rate 4×4 QOSTBC was developed as shown below,

$$\mathbf{G}_4 = \begin{pmatrix} \mathbf{G}_{12} & \mathbf{G}_{34} \\ -\mathbf{G}_{34}^* & \mathbf{G}_{12}^* \end{pmatrix} = \begin{pmatrix} x_1 & x_2 & x_3 & x_4 \\ -x_2^* & x_1^* & -x_4^* & x_3^* \\ -x_3^* & -x_4^* & x_1^* & x_2^* \\ x_4 & -x_3 & -x_2 & x_1 \end{pmatrix} \quad (10)$$

where G_{12} and G_{34} are the Alamouti encoders as in (6) and the subscript "12" denotes that the matrix has x_1 and x_2 , and also the subscript "34" has the same meaning.

With the assumption of a flat fading channel, Alamouti scheme can be applied on a 4×4 MIMO channel for four time slots. Hence, the virtual

channel matrix with four transmit time slots will be of size 16×4 as follows.

$$\mathbf{H}_{4,QOSTBC} = \begin{pmatrix} \mathbf{h}_1 & \mathbf{h}_2 & \mathbf{h}_3 & \mathbf{h}_4 \\ \mathbf{h}_2^* & -\mathbf{h}_1^* & \mathbf{h}_4^* & -\mathbf{h}_3^* \\ \mathbf{h}_3^* & \mathbf{h}_4^* & -\mathbf{h}_1^* & -\mathbf{h}_2^* \\ \mathbf{h}_4 & \mathbf{h}_3 & -\mathbf{h}_2 & -\mathbf{h}_1 \end{pmatrix}_{16 \times 4} \quad (11)$$

Alamouti decoding scheme in the receiver will yield,

$$\tilde{\mathbf{r}} = \mathbf{H}_{4,QOSTBC}^H \mathbf{r} = \mathbf{H}_{4,QOSTBC}^H \mathbf{H}_{4,QOSTBC} \mathbf{x} + \mathbf{H}_{4,QOSTBC}^H \mathbf{n} \quad (12)$$

Taken that $\Delta = \mathbf{H}_{4,QOSTBC}^H \mathbf{H}_{4,QOSTBC}$, and $\tilde{\mathbf{n}} = \mathbf{H}_{4,QOSTBC}^H \mathbf{n}$ then

$$\tilde{\mathbf{r}} = \Delta \mathbf{x} + \tilde{\mathbf{n}} \quad (13)$$

$$\Delta = \begin{pmatrix} \gamma & 0 & 0 & \alpha \\ 0 & \gamma & -\alpha & 0 \\ 0 & -\alpha & \gamma & 0 \\ \alpha & 0 & 0 & \gamma \end{pmatrix}_{4 \times 4} \quad (14)$$

$$\gamma = \sum_{k=1}^4 |\mathbf{h}_k^H \mathbf{h}_k| \quad (15)$$

$$\alpha = \text{Re}\{\mathbf{h}_1^H \mathbf{h}_4 - \mathbf{h}_2^H \mathbf{h}_3\} \quad (16)$$

Alamouti scheme for a 4×4 MIMO channel matrix does not give full orthogonal virtual channel matrix. Here, Δ is a quasi-orthogonal matrix having some non-zero terms out of its diagonal (γ and α). Quasi-orthogonal symbols reduce the diversity gain at the receiver [10].

The capacity of QOSTBC system has to be measured over four time slots (four symbols periods). The resulting system capacity is [7]:

$$C_{4,QOSTBC} = \frac{1}{4} \log_2 \left(\det \left(\mathbf{I}_N + \frac{\text{SNR}}{M} \mathbf{H}_{4,QOSTBC}^H \mathbf{H}_{4,QOSTBC} \right) \right) \quad (17)$$

2.5 Hybrid of BLAST and STBC Systems

The first study proposed the hybrid system was in ref. [7] when the authors completed a technical report. In their research, a new STBC-VBLAST scheme was introduced. If the number of STBC layers is J and each STBC layer has m transmit antennas, then the new system integrates J orthogonal $m \times p$ STBC symbols into VBLAST system's lower layers. The hybrid system has a total N receive and M transmit antennas.

The remaining first layers transmit independent symbol streams (BLAST). This structure aims to obtain multiplexing and diversity gains at the same time [5]. The transmitter block diagram for the hybrid G2+1+1 STBC-BLAST system is shown in Fig. 1.

In hybrid G2+1+1 system, the symbols sequences are divided into three streams. The first and second streams are transmitted on the first and second antennas respectively. In the same time, the third stream is transmitted through STBC encoder via the third and fourth antennas.

In ref. [29], an efficient encoder/decoder scheme was proposed, it sends the symbols in the first time slot and the negative conjugate of the symbols in the second time slot but the STBC encoder layers sent symbols as defined in Alamouti scheme (G2). The transmitted symbols can be formulated in a matrix form as:

$$\mathbf{x} = \begin{pmatrix} \mathbf{x}_{spa} \\ \mathbf{G}_2 \end{pmatrix} = \begin{pmatrix} x_1 & x_3 & x_5 & x_6 \\ -x_2^* & -x_4^* & -x_6^* & x_5^* \end{pmatrix}^T \quad (18)$$

where \mathbf{x}_{spa} is BLAST layers transmitted symbols. The wireless received signal is:

$$\mathbf{r} = \mathbf{H} \begin{pmatrix} \mathbf{x}_{spa} \\ \mathbf{G}_2 \end{pmatrix} + \mathbf{n} \quad (19)$$

The virtual wireless channel matrix is:

$$\mathbf{H}_{Hybrid} = \begin{pmatrix} \mathbf{H}_{4 \times 6} \\ \mathbf{H}_{4 \times 6}^* \end{pmatrix}_{8 \times 6} = \begin{pmatrix} \mathbf{h}_1 & 0 & \mathbf{h}_2 & 0 & \mathbf{h}_3 & \mathbf{h}_4 \\ 0 & -\mathbf{h}_1^* & 0 & -\mathbf{h}_2^* & \mathbf{h}_4^* & -\mathbf{h}_3^* \end{pmatrix}_{8 \times 6} \quad (20)$$

where \mathbf{h}_n is the n th column vector of \mathbf{H} .

$$\begin{pmatrix} r_1 \\ r_2 \end{pmatrix} = \begin{pmatrix} \mathbf{h}_1 & 0 & \mathbf{h}_2 & 0 & \mathbf{h}_3 & \mathbf{h}_4 \\ 0 & -\mathbf{h}_1^* & 0 & -\mathbf{h}_2^* & \mathbf{h}_4^* & -\mathbf{h}_3^* \end{pmatrix} (x_1 \ x_2 \ x_3 \ x_4 \ x_5 \ x_6)^T + \begin{pmatrix} \mathbf{n}_1 \\ \mathbf{n}_2 \end{pmatrix} \quad (21)$$

$$\mathbf{r} = \mathbf{H}_{Hybrid}^H \mathbf{r} = \mathbf{H}_{Hybrid}^H \mathbf{H}_{Hybrid} \mathbf{x} + \mathbf{H}_{Hybrid}^H \mathbf{n} \quad (22)$$

However, in MLSTBC G2+G2 system, the number of receive antennas have to be equal to at least the number of layers to apply Alamouti scheme. The Hybrid BLAST-STBC G2+G2 system architecture is shown in Fig. 2.

For a 4×4 MIMO system, and by using Alamouti scheme (G2) so $J = 2$, $M = 4$, $p = 2$ and $m = 2$.

$$\mathbf{x} = \begin{pmatrix} \mathbf{G}_2 \end{pmatrix} = \begin{pmatrix} x_1 & x_2 & x_3 & x_4 \\ -x_2^* & x_1^* & -x_4^* & x_3^* \end{pmatrix}^T \quad (23)$$

And the received signal on this channel matrix will be

$$\begin{pmatrix} r_1 \\ r_2 \end{pmatrix} = \begin{pmatrix} \mathbf{H}_A^1 & \mathbf{H}_A^2 \end{pmatrix} \mathbf{x} + \begin{pmatrix} \mathbf{n}_1 \\ \mathbf{n}_2 \end{pmatrix} \quad (24)$$

And by applying the criteria of Alamouti scheme the channel matrix is will be as follows

$$\mathbf{H}_{Hybrid} = \begin{pmatrix} \mathbf{H}_{4 \times 4} \\ \mathbf{H}_{4 \times 4}^* \end{pmatrix}_{8 \times 4} = \begin{pmatrix} \mathbf{h}_1 & \mathbf{h}_2 & \mathbf{h}_3 & \mathbf{h}_4 \\ \mathbf{h}_2^* & -\mathbf{h}_1^* & \mathbf{h}_4^* & -\mathbf{h}_3^* \end{pmatrix}_{8 \times 4} \quad (25)$$

$$\mathbf{H}_{Hybrid} = \begin{pmatrix} \mathbf{H}_{4 \times 4} \\ \mathbf{H}_{4 \times 4}^* \end{pmatrix}_{8 \times 4} = \begin{pmatrix} \mathbf{h}_1 & \mathbf{h}_2 & \mathbf{h}_3 & \mathbf{h}_4 \\ \mathbf{h}_2^* & -\mathbf{h}_1^* & \mathbf{h}_4^* & -\mathbf{h}_3^* \end{pmatrix}_{8 \times 4} \quad (26)$$

where \mathbf{h}_n is the n th column vector of $\mathbf{H}_{4 \times 4}$. $\mathbf{H}_{Hybrid}^H \mathbf{H}_{Hybrid}$ is a 4×4 channel matrix where any symbol detection scheme can be used at the receiver side.

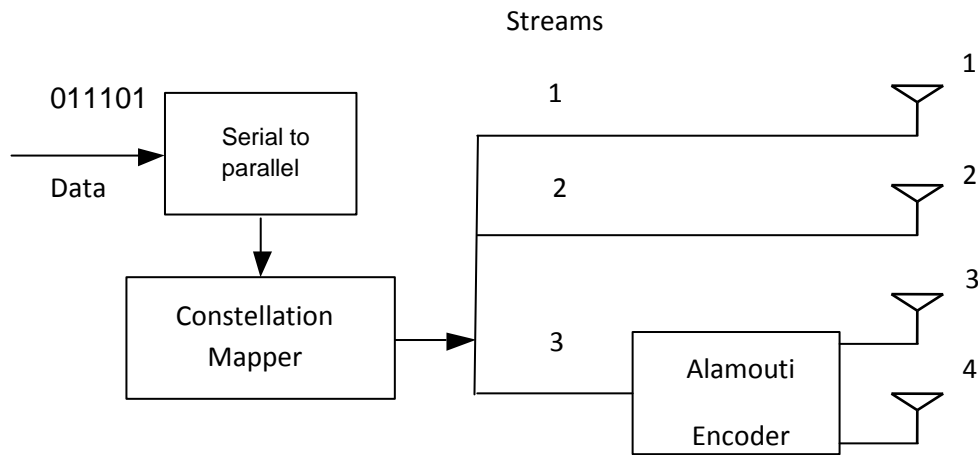

Fig. 1. Block diagram for hybrid G2+1+1 transmitter

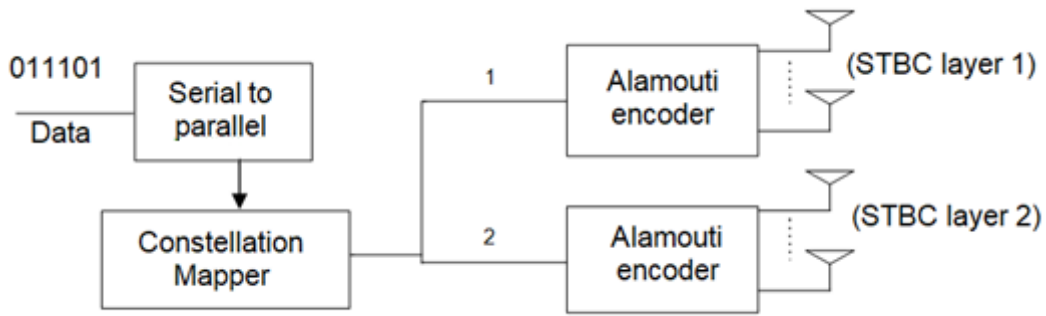

Fig. 2. Architecture of the hybrid BLAST STBC G_2+G_2 system

The general formula used to compute the Hybrid BLAST-STBC system capacity is:

$$C_{A,QOSTBC} = \frac{1}{p} \left(\det \left(I_N + \frac{SNR}{M} \mathbf{H}_{Hybrid}^H \mathbf{H}_{Hybrid} \right) \right) \quad (27)$$

2.6 Comparison between VBLAST, Hybrid STBC-BLAST and STBC Systems

This research concerns a 4×4 MIMO setup. An n -layer 4×4 MIMO system is the system that can transmit n symbols at a time slot, for example a 3-layer 4×4 MIMO uses 4 transmit antennas (as a transmit diversity) to transmit 3 symbols at a time slot. In ref. [30], a full detailed comparison study was published where the 4×4 MIMO system was analyzed by both theoretical and simulation results regarding channel capacity and BER, and it reported that:

- For a 3-layered MIMO system, the best results were achieved by using the hybrid G_2+1+1 system.
- For a 2-layered MIMO system, the best results were the hybrid G_2+G_2 system.
- For a single-layer MIMO system, the best result were achieved by the QOSTBC system.

Those results made a motivation for the authors to utilize them under the condition of transmit-link deep fading, where the CSI is not good.

3. PROPOSED ADAPTIVE SWITCHING HYBRID BLAST-STBC SYSTEM

In a 4×4 MIMO system, there are two antenna selection methods to improve the effective SNR, transmit antenna selection [14], and receive antenna selection [15]. This paper considers only the transmit antenna selection. The proposed ASHS system will be switched in order to maximize the throughput in all cases by sending

a training sequence of every scheme for every 2 dB change of received SNR and computing the throughput of all transmitted schemes. The simulation is done for every 2 dB change of SNR in the receiver side and this 2dB value is chosen arbitrary to show the simulation results.

ASHS always chooses the best transmission scheme based on the Channel State Information (CSI) obtained from the receiver assuming perfect channel estimation. ASHS implementation is based on the throughput maximization, where the system adapts the transmitted STBC scheme according to the channel fading level.

When any column's gain of \mathbf{H} is -20dB or less then this column is considered under deep fading. The number of the columns in \mathbf{H} at the receiver side refers to the number of transmit links at the transmitter side. ASHS implementation is based on the throughput maximization, where the system adapts the transmitted STBC scheme according to channel fading level.

The basic procedure for ASHS follows:

- At the beginning of the transmission VBLAST scheme is used.
- The receiver constantly measures and estimates current SNR and CSI.
- If 2 dB change in SNR is got, then the receiver sends a request of a training sequence.
- The transmitter sends a training sequence of every scheme without error correcting codes.
- The BER and Capacity for each transmission scheme are estimated.
- The transmission scheme that yields a maximum throughput is selected.

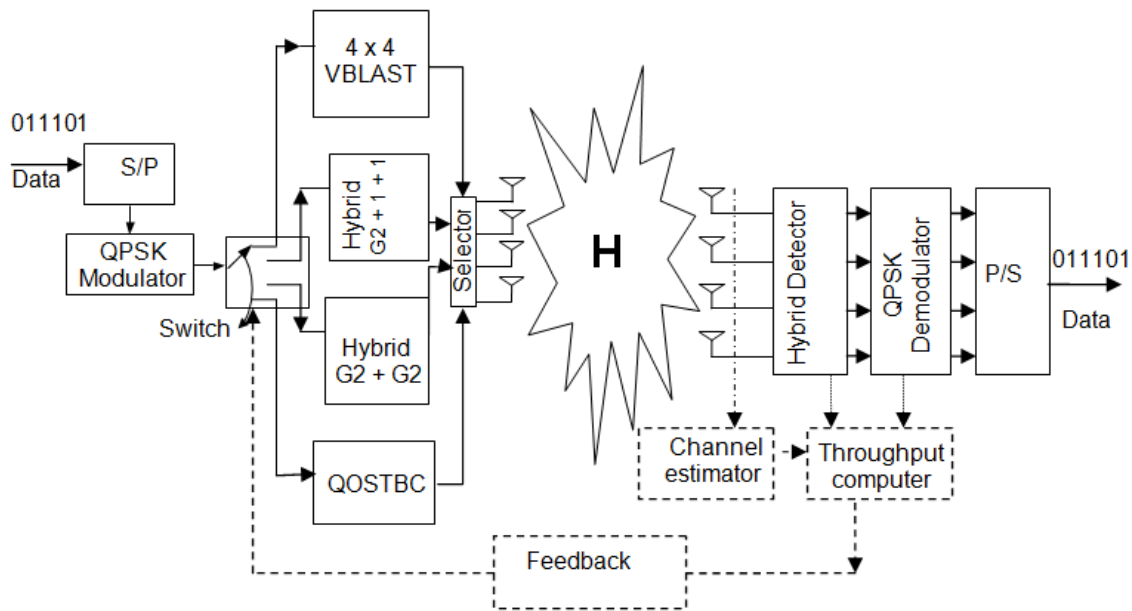

Fig. 3. Proposed adaptive switching hybrid system

- The receiver sends the decision of transmission scheme back to the transmitter via control channel or management frames. Both the receiver and the transmitter switch to the new transmission scheme.

ASHS can track the channel fading gains and adapt the transmission to be the best one for any change in the effective SNR but it takes a little time to transmit the training sequence, compute the best throughput and feedback the selected transmission mode to the transmitter. Fig. 3 illustrate the proposed system where QPSK modulation is used but it is appropriate for other modulation schemes.

4. RESULTS AND DISCUSSION

ASHS system of Fig. 3 works well in the case of transmit or receive link fading as well, sending a training sequence is the optimal solution rather than making a threshold-base selection.

Additionally, the effect of receive link fading on the effective SNR and the average capacity is as same as transmit link fading due to the effect of cancelling one column or more for transmit link fading and one row or more for receive link fading as stated in ref. [18].

4.1 ASHS for One Transmit Link Deep Fading

In the case of one transmit link fading; BER, capacity, and throughput of each system are shown in Fig. 4, Fig. 5, and Fig. 6. By default, ASHS system transmission was done by 4×4 VBLAST system until a change of ± 2 dB in SNR is sensed (which means a fade or improvement in channel may occur), then the transmitter sends training sequence (TS), the receiver computes the throughput of all schemes, and send a decision back to the transmitter. In the case of one transmit link deep fading, the decision is $G_2 + 1 + 1$ system, then ASHS switch to this transmission scheme as in Fig. 4, Fig. 5 and Fig. 6 and still using it until a 20 dB SNR is measured (which means a good CSI) then it will switch again to a 4×4 VBLAST system and still using it for all SNRs higher than 20 dB.

4.2 ASHS for 2 Adjacent Transmit Link Deep Fading

Fig. 7 shows that ASHS system will switch to $G_2 + 1 + 1$ system for a change of 2 dB in SNR. Although its BER is not so good, the throughput is the best until a 20 dB SNR is measured or higher, then ASHS system will switch to 4×4 VBLAST system. Fig. 8 shows that an 4×4 VBLAST and $G_2 + 1 + 1$ systems are at the same capacity bound and $G_2 + G_2$ system has a worse capacity and finally QOSTBC system has the

worst capacity but its throughput better than $G_2 + G_2$ system for SNR less than 16 dB as seen from Fig. 9.

4.3 ASHS for 2 Nonadjacent Transmit Link Deep Fading

Fig. 10 shows that ASHS system will switch to $G_2 + G_2$ system for a change of 2 dB in SNR, and its BER is very good and opposite to the BER performance of the 4×4 VBLAST and $G_2 + 1 + 1$

systems, also QOSTBC system shows a very good BER performance but with the worst capacity and throughput as seen in Fig. 11 and Fig. 12.

In Fig. 12, the throughput of $G_2 + G_2$ system is the best until higher than 17 dB SNR is measured then it will switch to 4×4 VBLAST system. Fig. 11 shows that 4×4 VBLAST, $G_2 + 1 + 1$ and $G_2 + G_2$ systems are at the same capacity bound.

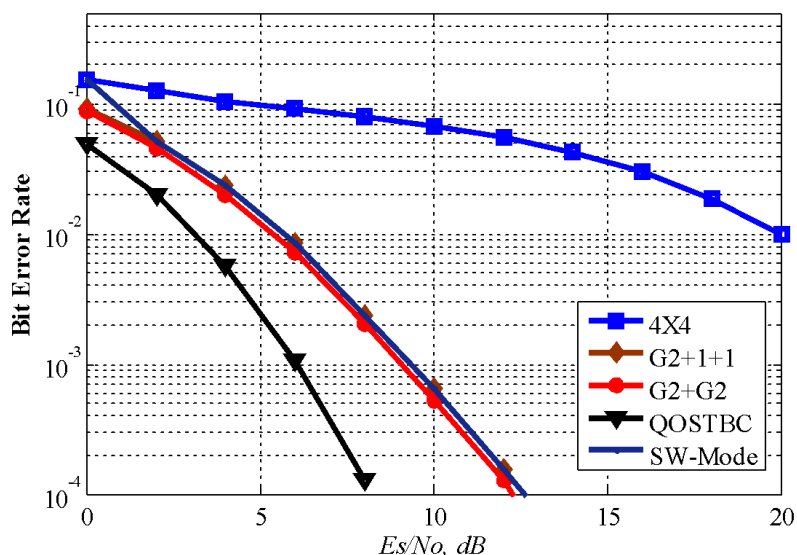

Fig. 4. BER of ASHS for 4th Tx link faded to -20 dB

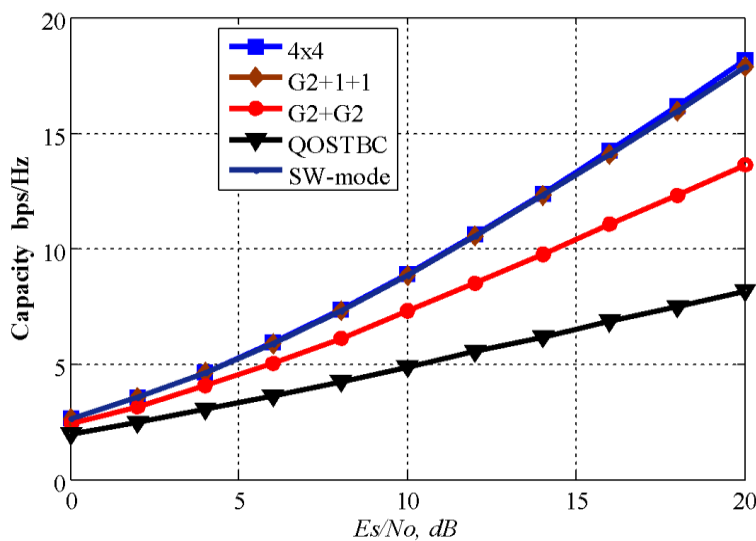

Fig. 5. Capacity of ASHS for 4th Tx link faded to -20 dB

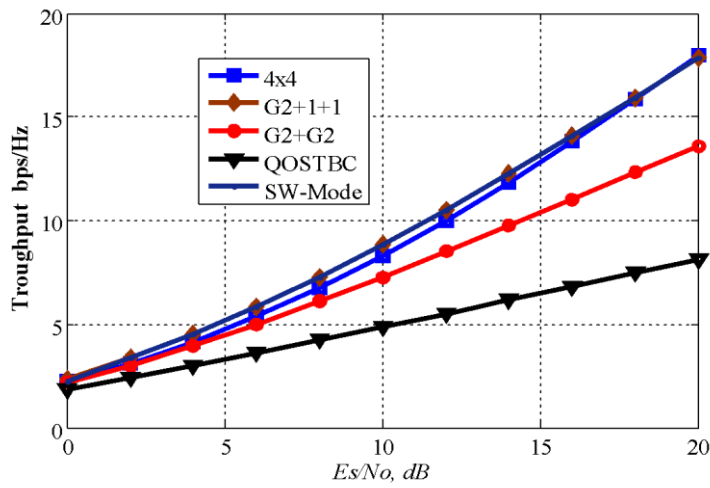

Fig. 6. Throughput of ASHS for 4th Tx link faded to -20 dB.

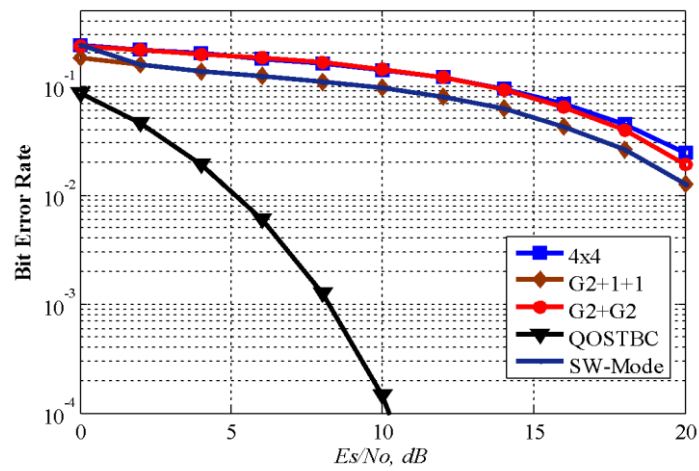

Fig. 7. BER of ASHS for 3rd and 4th Tx links faded to -20 dB

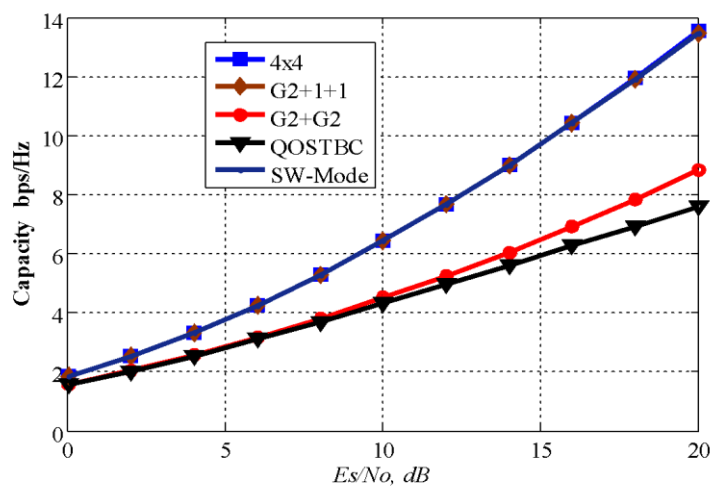

Fig. 8. Capacity of ASHS for 3rd and 4th Tx links faded to -20 dB

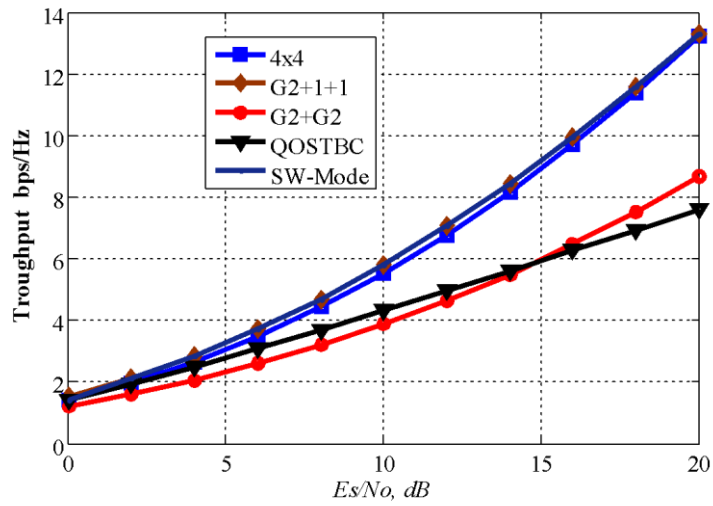

Fig. 9. Throughput of ASHS for 3rd and 4th Tx links faded to -20 dB

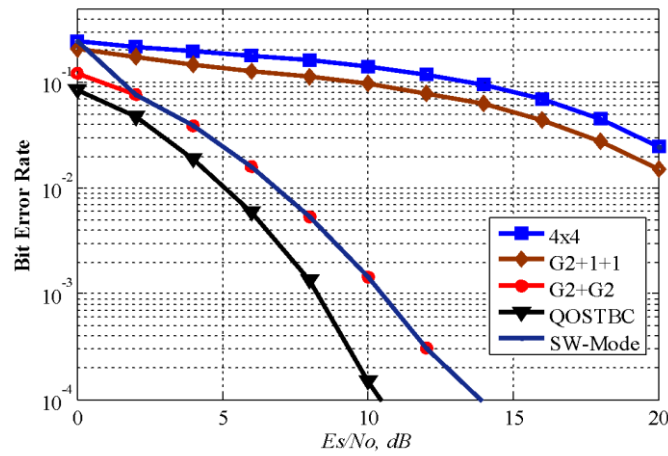

Fig. 10. BER of ASHS for 2nd and 4th Tx links faded to -20 dB

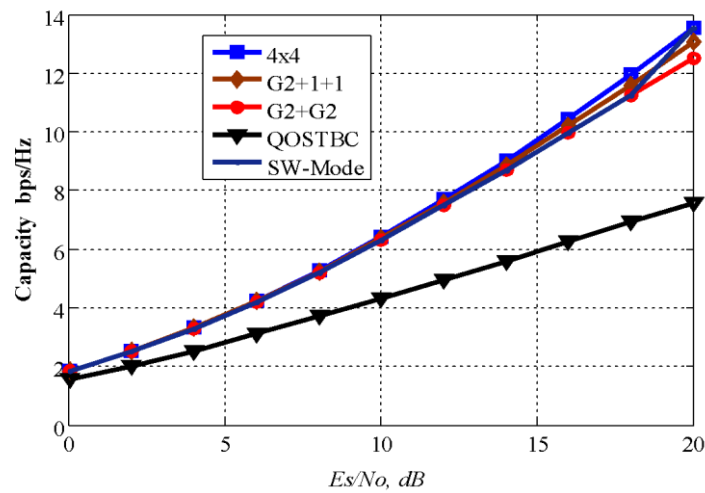

Fig. 11. Capacity of ASHS for 2nd and 4th Tx links faded to -20 dB

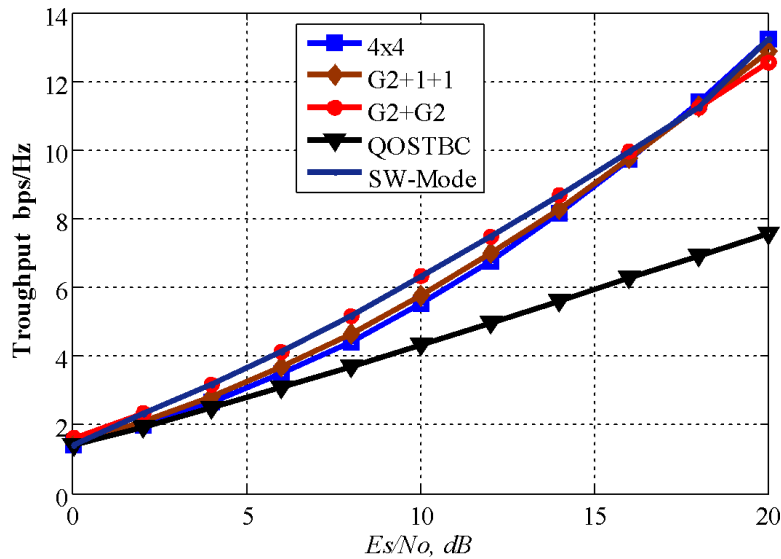

Fig. 12. Throughput of ASHS for 2nd and 4th Tx links faded to -20 dB

4.4 ASHS for 3 Adjacent Transmit Link Deep Fading

Fig. 13 shows that ASHS system will switch to QOSTBC system for a change of 2 dB in SNR and its BER is very good and opposite to the bad BER performances of 4 × 4 VBLAST, G₂ + 1 + 1 and G₂ + G₂ systems for SNR lower than 15 dB.

The ASHS system will switch to the G₂ + 1 + 1 system for SNR higher than 15 dB and lower than 20 dB. After 20 dB, the SNR is measured

and the ASHS system will switch to the 4 × 4 VBLAST system as seen in Fig. 13.

Fig. 14 shows that the 4 × 4 VBLAST, G₂ + 1 + 1, G₂ + G₂ and QOSTBC systems have the same capacity bound for SNR lower than 15 dB and there is some difference between them for higher SNR.

In Fig. 15, the throughput of QOSTBC system is the best until the measured SNR is above 15 dB then it will switch to G² + 1 + 1. The throughput of 4 × 4 VBLAST system is better for more than 20 dB SNR.

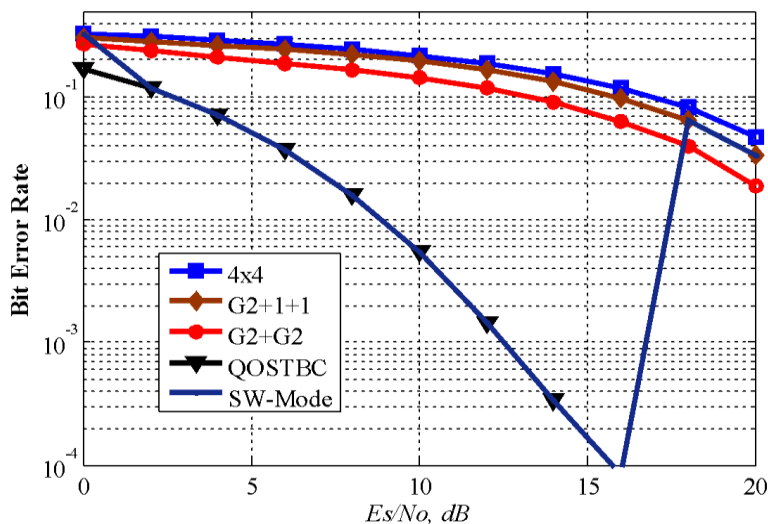

Fig. 13. BER of ASHS for 2nd and 3rd and 4th Tx links faded to -20 dB

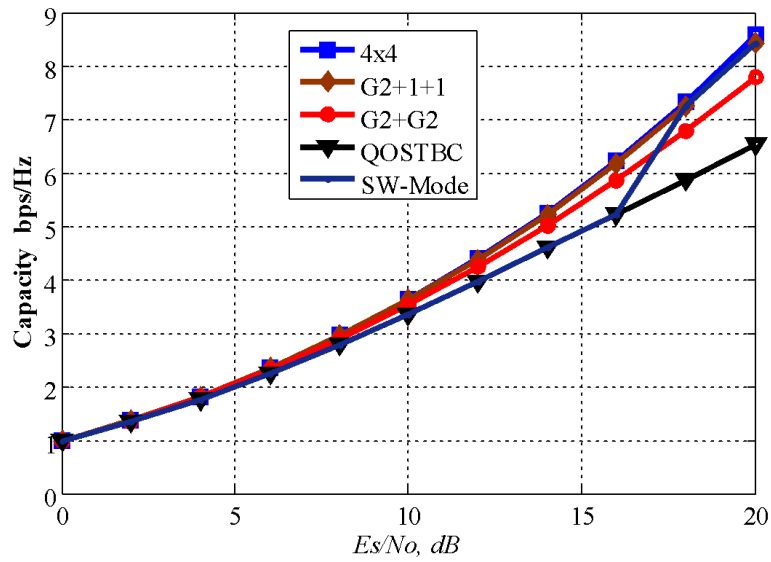

Fig. 14. Capacity of ASHS for 2nd and 3rd and 4th Tx links faded to -20 dB

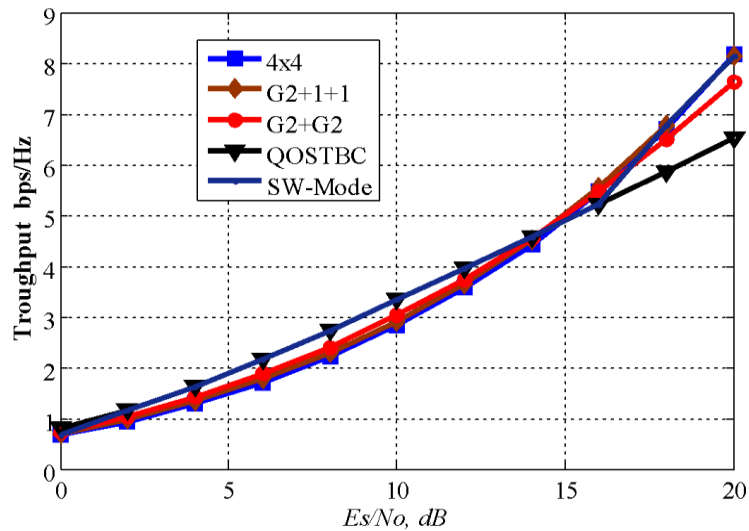

Fig. 15. Throughput of ASHS for 2nd and 3rd and 4th Tx links faded to -20 dB

4.5 ASHS all Transmit Link Deep Fading

As stated in ref. [18], this is the worst case scenario in deep fading cases, this channel is inefficient. Fig. 16 shows the BER performance of those systems, this case of fading make all BER performances very bad and a great loss of data is occurred. A low capacity bound is obtained and all systems capacities approximately the same as seen in Fig. 17 until the measured SNR is equal to 14 dB, then some improvements on

BER performances and capacities of these systems could be gained for SNR higher than 15 dB. Finally, the proposed ASHS system shows a lot of advantages such as:

- A maximum throughput is obtained in bad channel states
- No additional transmit power is needed.
- No additional bandwidth is needed. But, it suffers from some complexity and may suffer from switching effects.

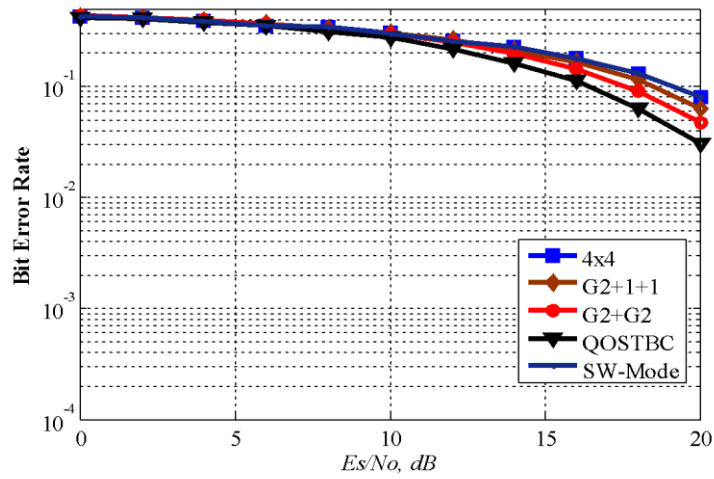

Fig. 16. BER of ASHS for all Tx links faded to -20 dB

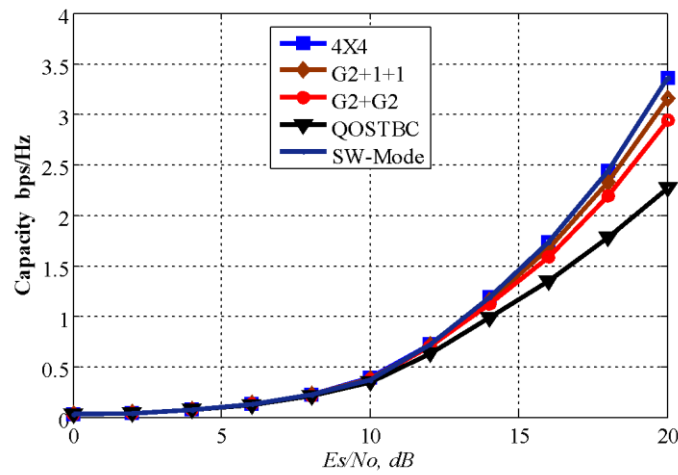

Fig. 17. Capacity of ASHS for all Tx links faded to -20 dB

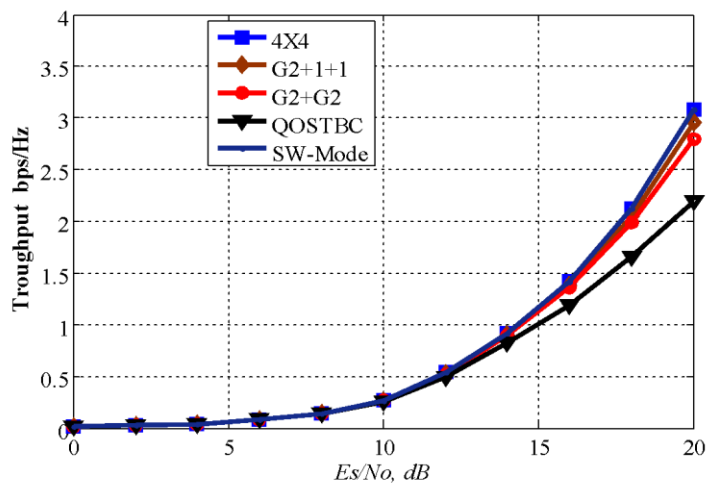

Fig. 18. Throughput of ASHS for all Tx links faded to -20 dB

5. CONCLUSION

In this research the effect of deep fading on different individual transmit links was simulated and analyzed again. It has been shown that the transmit link deep fading has the same effect on the effective SNR and the average capacity as the receive link deep fading in the previous research references. Also, a decision made for the best throughput system in each case.

A 4×4 VBLAST has the best throughput at high SNR in all cases, and $G2 + 1 + 1$ system prove itself for the case of deep fading of 3rd and 4th Tx links or any two adjacent Tx links, and $G2 + G2$ system was the best transmission scheme in case of deep fading of 2nd and 4th, 1st and 4th, 1st and 3rd or 2nd and 3rd Tx links (two nonadjacent transmit links). The QOSTBC system gives a very good BER and saves a lot of bits per second per Hz if any three transmit links are suffering from deep fading. Finally, no useful solution when all transmit links are deeply faded (below -20 dB). However, for some effective SNRs there are some bits could be saved.

The proposed ASHS system is simulated and analyzed. ASHS will be switched in order to maximizing the throughput in all cases through sending a training sequence of every scheme for every 2 dB change of the measured SNR at the receiver, and decision is made based on the maximum throughput transmission scheme. The decision is fed back to the transmitter. ASHS shows a lot of benefits such as a maximum throughput is obtained, no additional transmit power and no additional bandwidth is needed but it suffers from some complexity and switching effect. In future, more studies on the switching effects of ASHS can be conducted. The feedback over control channel delay effects on ASHS may be also considered for farther researches. Implementing and testing ASHS system on real-time communication hardware may open a new opportunities for research community.

COMPETING INTERESTS

Authors have declared that no competing interests exist.

REFERENCES

1. Wolniansky PW, Foschini GJ, Golden GD, Valenzuela RA. V-BLAST: An architecture for realizing very high data rates over the rich-scattering wireless channel. in 1998 URSI international symposium on signals, systems, and electronics. Conference proceedings (Cat. No. 98EX167). 1998;295–300.
2. Elshokry A, Abu-Hudrouss A. Performance evaluation of MIMO spatial multiplexing detection techniques. Al-Azhar Journal of Natural Science. 2012;14(14):47–60.
3. Alamouti SM. A simple transmit diversity technique for wireless communications. IEEE J. Sel. Areas Commun. 1998;16(8):1451–1458. DOI: 10.1109/49.730453
4. Jafarkhani H. Space-time coding: Theory and practice. 1st ed. New York: Cambridge university press; 2005.
5. Freitas WC, Cavalcanti FRP, Lopes RR. Hybrid MIMO transceiver scheme with antenna allocation and partial CSI at transmitter side. in 2006 IEEE 17th International Symposium on Personal, Indoor and Mobile Radio Communications. 2006;1–5.
6. Tran X, Ho H, Fujino T, Karasawa Y. Performance of detectors for combined STBC-SM systems. in Intern. Symp. Antennas Propagation (ISAP2007). 2007;1362–1365.
7. Mao T, Motani M. STBC-VBLAST for MIMO wireless communication systems. IEEE International Conference on Communications; 2005. DOI: 10.1109/icc.2005.1494739
8. Freitas WC, de Almeida ALF, Mota JCM, Cavalcanti FRP, de Lacerda Neto RL. Performance of MIMO antenna systems with hybrids of transmit diversity and spatial multiplexing using soft-output decoding. in International Conference on Telecommunications. 2004;28–37.
9. Doufexi A, Nix A, Beach M. Combined spatial multiplexing and STBC to provide throughput enhancements to next generation WLANs. IST Mobile and Wireless Communications Summit; 2005.
10. Sinha N, Chakraborty S, Bera A. Capacity enhancement of 4G-MIMO using hybrid BLAST STBC systems. Journal of Telecommunications. 2010;3(1):115–124.
11. Tarokh V, Naguib A, Seshadri N, Calderbank A R. Combined array processing and space-time coding. IEEE Transactions on Information Theory. 1999;45(4):1121–1128.

- DOI: 10.1109/18.761255.
12. Gonzalez G, Cortez J, Bazdresch M. Reduced complexity tree-search detector for hybrid space-time codes. in 2019 IEEE Western New York Image and Signal Processing Workshop (WNYISPW). 2019;1–5.
DOI: 10.1109/WNYIPW.2019.8923103
 13. Lee W C. Mobile communications engineering. 1st ed. USA: McGraw-Hill Professional; 1982.
 14. Dong X. Effect of slow fading and adaptive modulation on TCP/UDP performance of high-speed packet wireless networks. University of California, Berkeley. Technical Report No. UCB/EECS-2006-109; 2006.
Available:<http://www.eecs.berkeley.edu/Pubs/TechRpts/2006/EECS-2006-109.htm>
2006
 15. Vieira P, Queluz P, Rodrigues A. Improving MIMO spectral efficiency in 4G macro-cellular networks. In proceedings. URSI Seminar of the Portuguese Committee. 2008;1:1-1.
 16. Song D, Chen C W. Novel layered scalable video coding transmission over MIMO wireless systems with partial CSI and adaptive channel selection. In Proceedings of the International Society for Optical Engineering. 2007;6507:65070R.
DOI: 10.1117/12.705680
 17. Nguyen HT, Andersen JB, Pedersen GF. On the performance of link adaptation techniques in MIMO systems. Wireless Personal Communication. 2007;42(4):543–561.
Available:www.doi.org/10.1007/s11277-006-9210-y
 18. Salemdeeb M, Abu-Hudrouss A. Deep fading effect on an individual link of 4×4 MIMO communication systems. An-Najah University Journal for Research - Natural Sciences. 2014;28:21-32.
 19. Salemdeeb M, Abu-Hudrouss A. Comparative study for the performance of VBLAST, QOSTBC and hybrid BLAST-STBC MIMO system under transmit link deep fading. International Journal of Electronics Communication and Computer Engineering. 2018;9(6):161-168.
 20. Kamruzzaman MM, He W, Peng X. Performance of relay assisted uplink wireless communication using multi-layered STBC for multiple access channel. Telecommunication Systems. 2019 ;7(1):309–320.
DOI: doi.org/10.1007/s11235-018-0493-6
 21. Hung HS., Lu HY, Cheng YH. A low-complexity genetic algorithm for joint antenna selection and power allocation in hybrid STBC-SM MIMO systems. Wireless Personal Communications. 2016;88:305–318.
DOI: org/10.1007/s11277-015-3119-2
 22. Osman M, Abuelenin S., Soliman H, Al-Barbary K. Performance analysis of a multi-layered SVD based STBC system. Wireless Personal Communications. 2017;96(2).
 23. Foschini GJ. Layered space-time architecture for wireless communication in a fading environment when using multi-element antennas. Bell Labs Technical Journal. 1996;1(2):41–59.
DOI: 10.1002/bltj.2015
 24. Andrews JG, Ghosh A, Muhamed R. Fundamentals of WiMAX: Understanding broadband wireless networking. 1st ed. United States: Prentice Hall; 2007.
 25. Sandhu S, Paulraj A. Space-time block codes: A capacity perspective. IEEE Communication Letters. 2000;4(12):384–386.
DOI: 10.1109/4234.898716
 26. Sanayei S, Nosratinia A. Antenna selection in MIMO systems. IEEE Communications Magazine. 2004;42(10):68–73.
DOI: 10.1109/MCOM.2004.1341263
 27. Gharavi-Alkhansari M, Gershman AB. Fast antenna subset selection in MIMO systems. IEEE Transactions on Signal Processing. 2004;52(2): 339–347.
DOI: 10.1109/TSP.2003.821099
 28. Jafarkhani H. A quasi-orthogonal space-time block code. IEEE Transactions on Communications. 2001;49(1):1–4.
DOI: 10.1109/26.898239
 29. Cortez J, Bazdresch M, Garcia A, Campoy JM, Pizarro A. An efficient detector for STBC-VBLAST space-time code for MIMO wireless communications. in Electronics, Robotics and Automotive Mechanics Conference (CERMA). 2009;44–49.
DOI: 10.1109/CERMA.2009.71

30. Salemdeeb M, Abu-Hudrouss A. Performance and capacity comparison between hybrid BLAST-STBC, VBLAST and STBC systems. International Journal of Emerging Technology and Advanced Engineering. 2012;2(10):12-22

© 2021 Salemdeeb and Abu-Hudrouss; This is an Open Access article distributed under the terms of the Creative Commons Attribution License (<http://creativecommons.org/licenses/by/4.0>), which permits unrestricted use, distribution, and reproduction in any medium, provided the original work is properly cited.

Peer-review history:
The peer review history for this paper can be accessed here:
<https://www.sdiarticle4.com/review-history/70983>