



Development of a Preconditioning System for FUTA Floating Fish Feed Extruder

A. P. Olalusi¹, C. F. Nwaeche^{2*} and A. Adesina¹

¹*Department of Agricultural and Environmental Engineering, School of Engineering and Engineering Technology, Federal University of Technology, Akure, Ondo State, Nigeria.*

²*Project Design and Development Department, Federal Institute of Industrial Research, Oshodi, Lagos, Nigeria.*

Authors' contributions

This work was carried out in collaboration between all authors. Author APO conceptualized, designed and supervised the study. Author CFN managed the literature search, CAD drawings, fabrication of the equipment and drafting of the manuscript. Author AA was the fabricator. All authors read and approved the final manuscript.

Article Information

DOI: 10.9734/JERR/2018/v3i216873

Editor(s):

(1) Dr. Ahmed Bdour, Professor, Water Resources and Environmental Engineering, Department of Civil Engineering, The Hashemite University, Jordan.

Reviewers:

(1) Felix Eze, Nigerian Maritime University, Nigeria.

(2) Şükrü Kitiş, Dumlupınar University, Turkey.

(3) Johnny Ogunji, Alex Ekwueme Federal University Ndufu Alike Ikwo, Nigeria.

Complete Peer review History: <http://www.sciencedomain.org/review-history/28099>

Original Research Article

Received 07 October 2018

Accepted 17 December 2018

Published 03 January 2019

ABSTRACT

The need to enhance the quality of fish feed produced in Nigeria was the major consideration in the design and development of a preconditioning system. The machine consists of two insulated cylindrical barrels, set of arranged paddles on a shaft, frame, hot water and feed mash inlet, discharge chute, chain and sprocket. It was powered by a three-phase 15 hp electric motor which transmits power to the machines shaft and set of paddles via chain and sprocket. The performance characteristics of the machine; mixing efficiency and throughput capacity were evaluated using Nigerian Institute for Oceanography and Marine Research (NIOMR) feed formulation at feed mash particle sizes of 900 µm, 550 µm, 520 µm and paired paddle rotating speed of the lower and upper chamber at (96.8; 145.2), (122.6; 183.2) and (174.5; 260.8) rpm respectively. The throughput capacity of the preconditioner is 650 kg/hr. The results showed increase in temperature and moisture content level of the particles as the machine speed decreases. The optimum mixing efficiency that gave best uniformity of mix was attained when Paired paddle speeds were (96.8; 145.2), (122.6; 183.2) with an average Biot numbers of 0.1.

*Corresponding author: Email: chiemerie77@gmail.com;

Keywords: Design; preconditioner; mixing efficiency; throughput capacity; Biot number.

1. INTRODUCTION

Feed formulation is a scientific method of combining available feed ingredients to meet the pre-determined nutrients requirements for a particular fish specie in a cost-effective way [1]. Fish feed can be classified into natural and artificial diet [2]. Natural fish feeds are sourced from natural waters or well-fertilized ponds which are balanced diet that help fishes grow strong and healthy. Examples of this food source are microscopic plants (phytoplankton), microscopic animals (zooplankton), insects, crustaceans, copepods and molluscs [3]. Artificial feeds can be complete or supplementary diets. Complete diets supply all the ingredients (protein, carbohydrates, fats, vitamins, and minerals) necessary for optimal growth and health of the fish in the right proportion. Most of this complete diet are formulated with protein (18-50%), lipid (10-25%), carbohydrate (15-20%), ash (< 8.5%), phosphorus (< 1.5%), water (< 10%), and trace amounts of vitamins, and minerals. While supplementary diet is used only to support the natural feeds with energy-based food in form of carbohydrate, proteins and fats & oil, but does not contain minerals and vitamin [2]. They can be used in all fish culture system. Artificial feeds also known as commercial fish diets can be manufactured using well-compounded mixture of feedstuffs and can be extruded (floating or buoyant) or pelleted (sinking) feeds [2]. Over N800billion is the estimated revenue generation when indigenous feed manufacturers are given enabling environment as fish feed consumption increases daily [4]. The estimated quantity of imported fish feed from European countries into Nigeria annually stand at 4000 tons [5], this reduces the country's foreign exchange earnings as few manufacturers that have ventured into production of fish feed in the country produce low quality feeds, import most of the key equipment used, which are very expensive and costly to maintain. The fishery industry has not achieved its goal of employment and social peace because the system is not operating in a sustainable and efficient manner [6]. Sustainable growth of aquaculture depends on different factors such as processability of the raw material, feed formulation and production techniques etc. [7]. In commercial fish feed production, certain steps are taken to achieve extruded or pelleted feeds. They are selection of ingredients, grinding, mixing, preconditioning and extrusion, cooling

and drying [8]. Preconditioning which is one of the unit operations in fish feed production is neglected by most manufacturers in Nigeria in order to reduce cost of production. The goal for preconditioning is to hydrate, pre-heat and mix powdery raw materials with injected fluids (steam, water and potentially oil or slurries) to obtain a homogeneous pre-cooked product that is best adapted to the next stage in fish feed production line. This operation improves extruder efficiency and reduces energy consumption, equipment wear and maintenance cost [9]. Preconditioning systems allow greater flexibility in controlling process parameters like temperature and moisture which extruders lack that affects the quality of the feed [10]. Extruders has low residence time (< 1min) [11]. It is important to proper hydrate and heat up the feed mix before introducing it into the extruder because process conditions used has an effect on the extrudite [12]. With no known report on any existing preconditioning system for fish feed production developed in Nigeria, this research to develop a preconditioning system for fish feed production was conceptualized with the aim of improving the feed quality produced by the newly developed FUTA fish feed extruder which can be adopted to suit other extruders in Nigeria.

2. METHODOLOGY

2.1 Design Considerations

The preconditioner was designed based on the following considerations:

- i. The choice of materials used was based on their quality, availability, durability, efficiency, workability, desired goal and their suitability for construction.
- ii. Preconditioner technology requires injection of heat and moisture in a closed system, so proper insulation material was used on the body frame of the equipment to retain heat inside the mixing chamber which reduces heat loss and burns to the user.
- iii. Aesthetics was considered for the equipment to be appealing to consumers.
- iv. The paddles were designed to achieve uniform mixing efficiency.
- v. The assembly of the machine was made simple for easier maintenance.

2.2 Description of Machine

The preconditioner as shown in Figs. 1 and 2, consists of the paddles and shaft arrangement made of stainless steel for mixing and conveying the preconditioned feed mash. The internal cylindrical barrels (upper and lower chambers) are made of stainless steel and insulated with a Polyurethane foam to retain heat during mixing and held in place by a removable cover. They are supported by a frame made of 75 × 75 mm mild steel angle iron to withstand tensional and vibrational stress. The machine is powered by 15 hp electric motor operating at speed of 1460 rpm. A reduction gear of ratio 5:1 which transmits power to the chain and sprockets that rotates the two shafts carrying the well-arranged sets of paddles. The different components of the preconditioner were designed and selected using standard engineering principle.

2.3 Operational Principle of the Fish Feed Preconditioner

The feed mash and hot water were introduced into the upper chamber of the machine through the feed mash and hot water inlet pipes simultaneously. The feed mash was hydrated, heated and conveyed radially into the lower chamber at high speed before being transferred to the discharge chute at reduced speed to increase retention time for adequate mixing of

feed. The paddle angle between the two rotating shafts were configured such that though the shafts moved in the same direction, the feed mash were conveyed in the opposite direction.

2.4 Design Calculation

2.4.1 Determination of the upper chambers internal surface area

The chamber is made up of stainless steel. Welded on this chamber are hot water/oil inlet, feed mash inlet and discharge outlet connecting the lower chamber. They all cylindrical in shape.

Let the surface area of the cylindrical parts is given by

$$C_A = 2\pi r(r + h) \quad (1)$$

Surface area of the inlet and outlet unit on the upper chamber

$$C_B = 2\pi r(r + h) \times 2 \quad (2)$$

Surface area of the hot water inlets (7 in number) on the upper chamber

$$C_C = 2\pi r(r + h) \times 7 \quad (3)$$

$$\text{Total area, } T_A = C_A + C_B + C_C \quad (4)$$

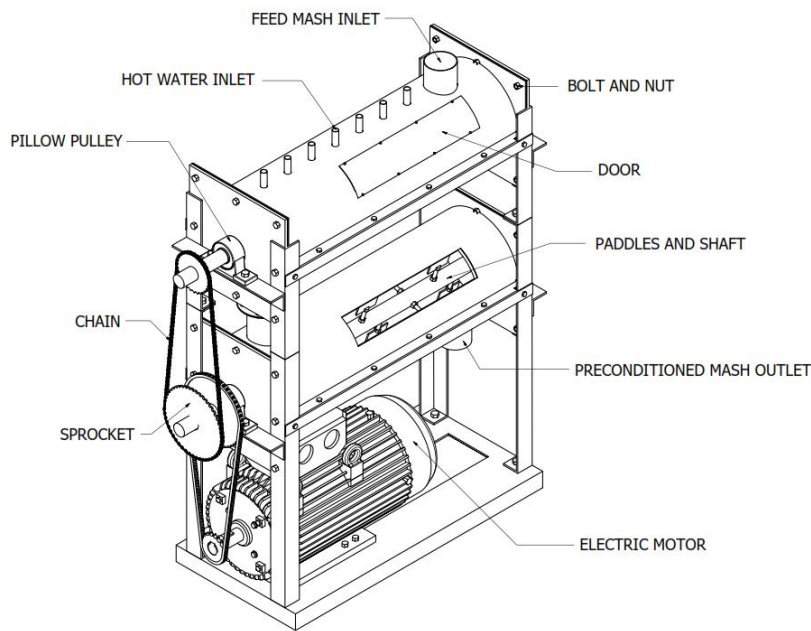

Fig. 1. Isometric view of the fish feed preconditioner

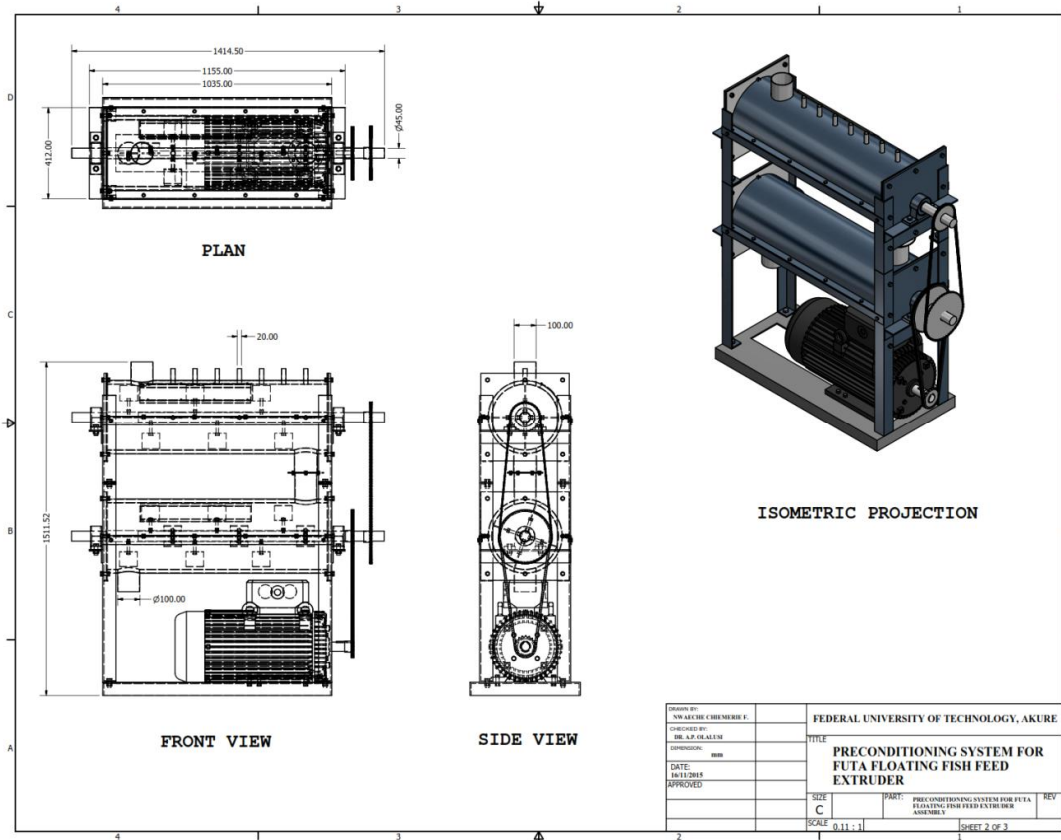

Fig. 2. Orthographic projection of the machine

2.4.2 Determination of the lower chambers internal surface area

The chamber is made up of stainless steel. Welded on it are mash inlet connecting the upper chamber and discharge chute. They are cylindrical in shape. The dimension used in the upper chamber for C_A and C_B was also used for the lower chamber.

$$\text{Total area, } T_A = C_A + C_B \quad (5)$$

2.4.3 Determination of the volume and mass of the upper internal chamber

$$\text{Density} = \frac{\text{Mass}}{\text{Volume}} \quad (6)$$

Density of stainless steel = 7930 kg/m³

$$\therefore \text{Volume} = \text{Area} \times \text{Thicknes}(C_A + C_B + C_C) \quad (7)$$

$$\therefore \text{Mass} = \text{Volume} \times \text{Density} \quad (8)$$

2.4.4 Determination of the volume and mass of the lower internal chamber

$$\text{Density} = \frac{\text{Mass}}{\text{Volume}}$$

$$\begin{aligned} \text{Density of stainless steel} &= 7930 \text{ kg/m}^3 \\ \therefore \text{Volume} &= \text{Area} \times \text{Thicknes}(C_A + C_B) \quad (9) \end{aligned}$$

2.4.5 Design of chain and sprockets

The chain drive system of this machine is made up of two chain and sprocket assemblies. One connecting the drive and lower chamber and the other connecting the lower and upper chamber of the machine. Based on investigation of existing preconditioners a rotational speed ranging from 150 – 400 rpm was selected for both chambers.

A moderate shock service condition with service factors (K_s) was selected from the manufacturer's catalogue.

$$K_s = K_1 \times K_2 \times K_3 \quad [13]$$

where, K_1 is load factor = 1.25, for mild shock
 K_2 is lubrication factor = 1.5, for periodic lubrication
 K_3 is rating factor = 1, for 8 hours per day

2.4.6 Lower and upper chamber chain drive system

Velocity ratio of a chain drive is given by

$$V \times R = \frac{N_1}{N_2} = \frac{T_2}{T_1} \quad [13]$$

Where N_1 is speed of rotation of driving sprocket
 N_2 is speed of rotation of driven sprocket
 T_1 is number of teeth on the larger sprocket
 T_2 is number of teeth on the smaller sprocket

Design power = rated power × service factors

2.4.7 Determination of pitch circle diameter of the driving and driven sprockets

$$d_1 = \frac{P}{\sin\left(\frac{180}{T_1}\right)} \text{ and } d_2 = \frac{P}{\sin\left(\frac{180}{T_2}\right)} \quad [13]$$

Where d_1 and d_2 is pitch circle diameter of driving and driven sprocket respectively
 P is chain pitch
 T_1 and T_2 is number of teeth of the driving and driven sprocket respectively.

2.4.8 Pitch line velocity of the driving sprocket

$$V_1 = \frac{\pi d_1 N_1}{60} \quad [13]$$

Where d_1 is pitch circle diameter of driving sprocket
 V_1 is pitch line velocity
 N_1 is speed of rotation of driving sprocket

Total load on the driving side of the chain, W

$$W = \frac{\text{rated power}}{\text{pitch line velocity}} \quad [13]$$

Design of power transmitted on the basis of breaking load, W_B

Breaking load $W_B = 106p^2$ (in Newton) for roller chains. [13]

Where p is chain pitch

Safety factor, $n = \frac{W_B}{W}$ [13]

Power transmitted, $P = \frac{W_B \times V_1}{n \times K_s}$ [13]

Chain velocity, $V = \frac{T_1 P N_2}{60}$ [13]

Where T_1 is number of teeth in the driving sprocket
 N_2 is speed of rotation of the driven sprocket
 P is chain pitch

Tangential driving force,

$$F_T = \frac{\text{power transmitted (in watts)}}{\text{speed of chain in m/s}} \quad [13]$$

Centrifugal tension in the chain, $F_C = mv^2$ [13]
Tension in the chain due to sagging, $F_S = Kmgx$

Where m is mass of the chain per metre
 x is centre distance
 g is acceleration due to gravity
 K is constant [13]

Total tension on the driving side of the chain, $T_T = F_T + F_C + F_S$

2.4.9 To calculate the centre distance between the sprockets

The minimum allowable centre distance between the driving and driven sprocket should be 30 to 50 times the pitch. Thus, for this model 30 times the pitch is selected.

$$30p = 30 \times 25.4$$

In order to accommodate initial, say in the chain, the value of centre distance is reduced by 2 to 5mm

$$\text{Correct centre distance, } x = 762 - 4 \quad [13]$$

2.4.10 To calculate number of chain links

$$K = \frac{T_1 + T_2}{2} + \frac{2x}{P} + \left[\frac{T_2 + T_1}{2\pi} \right]^2 \frac{P}{x} \quad [13]$$

2.4.11 To calculate chain length

$$L = K \times P \quad [13]$$

2.4.12 Design of shaft

2.4.12.1 Lower and upper chamber shaft design

Maximum bending moment

$$M_b = \sqrt{M_v^2 + M_H^2} \quad [13]$$

Torsional moment M_t for the shaft

$$M_t = \frac{P \times 60}{2\pi n} \quad [13]$$

Where P is the design power in watts and n is the speed of rotation in rpm for the driven sprocket.

2.4.13 Diameter of the shaft

The diameter of the shaft is given by

$$d^3 = \frac{16}{\pi S_s} \sqrt{(K_b M_b)^2 + (K_t M_t)^2} \quad [13]$$

Where K_b and K_t are combined shock and fatigue factors applied to bending moment and torsional moment.

S_s is allowable stress for shaft with key way = 42 MN/m²

K_b and K_t are 1.5 and 1.0 respectively for rotating shaft.

Shaft is usually subjected to axial bending and torsional loads

For solid shaft

$$\text{Tensile stress} = \frac{4f_a}{\pi d^2}$$

f_a is the reaction at bearings close to the chain and sprocket on the shaft of the upper and lower chambers

Bending load for lower and upper chamber shaft

$$\text{Bending stress} = \frac{32M_b}{\pi d^3}$$

2.5 Preliminary Test

The composition of the feed mash ingredient used and volume of water added in the mixture during the preliminary testing were suggestions by Nigerian Institute for Oceanography and Marine Research (NIOMR). The Table 1 shows the percentage composition by mass of the different ingredients used.

Table 1. Fish feed mass formulation used

S/N	Ingredient	Percentage composition by mass (%)
1.	Cassava flour	39
2.	Soymeal	20
3.	Groundnut Cake	20
4.	Fish meal	20
5.	Fish premix	0.5
6.	Nitox Antimould	0.5

Source: Nigerian Institute for Oceanography and Marine Research (NIOMR)

The machine was tested by varying feed mash particle sizes of 900, 550 and 520 μm . The

machine paddle speed were in pairs of (96.8; 145.2), (122.6; 183.2) and (174.5; 260.8) rpm. The first and second values in the bracket represents the paddle speed of the lower and upper chamber respectively. The initial moisture content and temperature of the formulated fish feed were taken before each run. Hot water at 100 °C and feed mash were introduced into the preconditioner simultaneously at rate of 2 litres per 13 kg batch. At the discharge, the weight of the final temperature and moisture content of the preconditioned feed were all determined. The thermal conductivity and volumetric heat capacity was determined using a single instrument called KD2 Pro which has 30 mm dual-needle sensor that was inserted into the feed mash which measures and displays its reading. Each run was repeated three times and their average was used for analysis. The throughput capacity and mixing efficiency were determined to calculate the performance indices of the machine.

Throughput capacity T_p , was determined using equation (6) below.

$$T_p = \frac{W}{t} \quad (6)$$

Where, T_p is throughput capacity (kg/h)

W is weight of the feed mash collected (kg)

t is time taken for preconditioning (h)

2.5.1 Determination of mixing efficiency of the preconditioner

The mixing efficiency of the preconditioner was determined using the dimensionless Biot number Bi that is generated after mixing; when the Biot number (Bi) is less than 0.1 it means the preconditioner mixes poorly, intermediate when is approximately 1 and good mixing when the Biot number is greater than 10 [14]. Biot number is given by

$$Bi = \frac{\lambda r}{\alpha} \quad (10)$$

where $\lambda = h_{fp}$ which is heat transfer coefficient ($\text{W}/\text{m}^2/^\circ\text{C}$)

α is thermal conductivity ($\text{W}/^\circ\text{C}/\text{m}$)

r is radius sphere of the feed mash particle (m) [15]

$$\therefore h_{fp} = \frac{Q_{fp}}{A\Delta T} \quad (11)$$

where A is total area of the particles in the control volume

ΔT is temperature difference between fluid and particle temperature ($^{\circ}\text{C}$) [16]

$$\therefore Q_{fp} = Q_{fluid} - Q_{paste} \quad (12)$$

where

Q_{fp} is heat flow from the fluid to the particles (W)

Q_{fluid} is convective heat flow of the fluid into the particles (W)

Q_{paste} is convective heat flow out of the paste (W)

$$Q_{fluid,paste} = mcp(\theta_1 - \theta_2) \quad (13)$$

where cp is volumetric heat capacity of the particles (MJ/m^3)

θ_1 is initial temperature of the particles and water ($^{\circ}\text{C}$)

θ_2 is final temperature of the particles and water ($^{\circ}\text{C}$)

m is mass of the fluid and particles (kg)

Substituting equation (13) in (12)

$$Q_{fp} = mcp(\theta_1 - \theta_2) - mcp(\theta_1 - \theta_2) \quad (14)$$

3. RESULTS AND DISCUSSION

The graphs below show the effect of the paired paddle speed on final moisture content and temperature of the preconditioned feed mash, residence time and mixing efficiency.

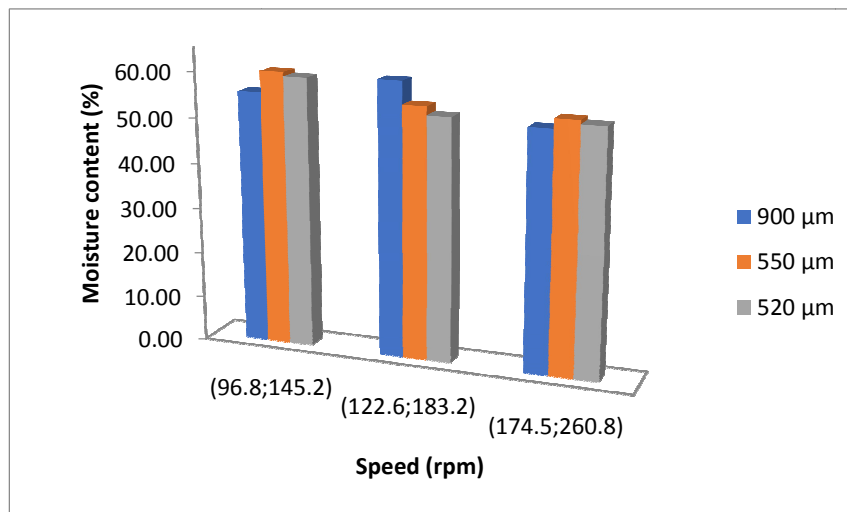

Fig. 3. Variation in the moisture content with paired paddle speed in rpm and particles

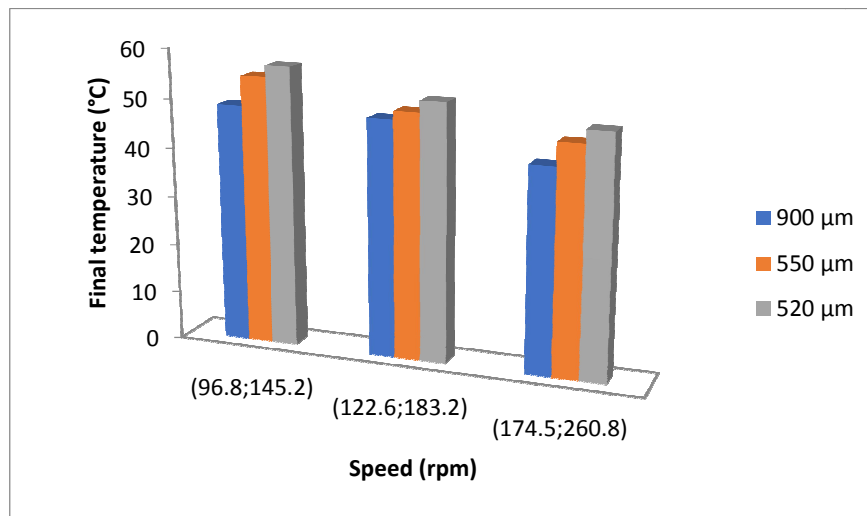

Fig. 4. Variation in final temperature with paired paddle speed in rpm and particles

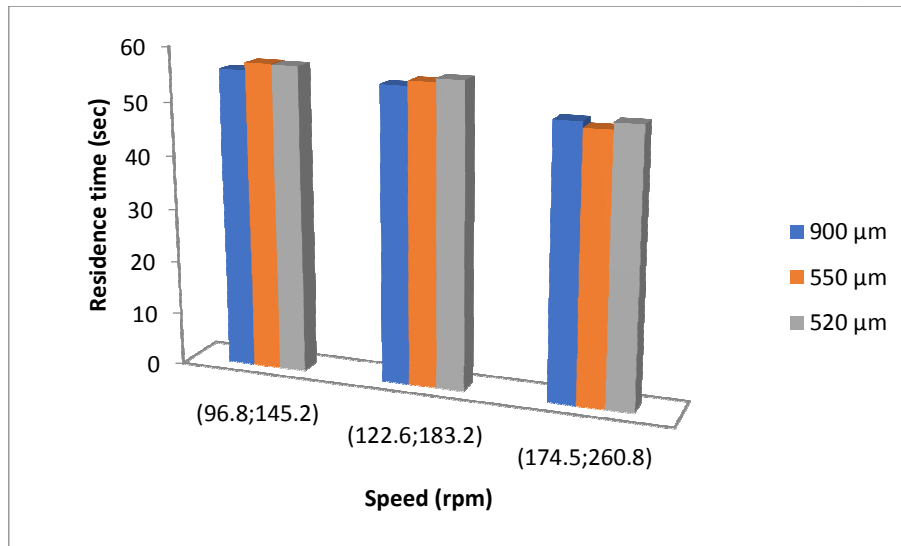

Fig. 5. Variation in residence time with paired paddle speed and particles

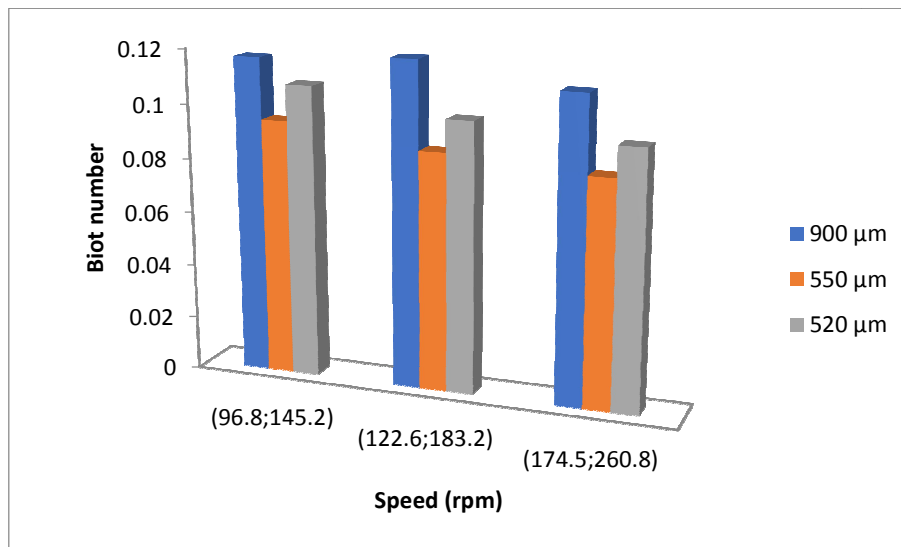

Fig. 6. Variation in Biot number with paired paddle speed in rpm and particles

Figs. 4, 5 and 6 shows that at paddle speed 174.5 and 260.8 rpm, the average retention time for all the particles was 49.9 seconds. At this speed the feed mash discharged at a low temperature and moisture content level. The average temperature and moisture reading were 44.3°C and 52.2 %, respectively. At paddle speed 122.6 and 183.2 rpm, the average retention time for all the particles was 55.46 seconds. This showed slight increase in temperature and moisture content level readings which averaged 47.6°C and 55.1 % respectively due to increase in retention time. There were

significant increase in temperature and moisture content reading at paddle speeds of 96.8 and 145.2 rpm. The average temperature and moisture content readings were 52°C and 58.8%, respectively and an average retention time of 57.12 seconds for all the particles. This showed that all the particles absorbed more moisture and heat as the paired paddle speed of the preconditioner reduces with increasing retention time. This agrees with report by Eugenio (2004), that higher residence time improves the hydration and heat absorption rate of the preconditioned feed mash.

Fig. 6 shows that, at paddle speed of 174.5 and 260.8 rpm, the average Biot number of all the particles was 0.09. However, at paddle speed of (122.6 and 183.2 rpm) and (96.8 and 145.2 rpm) the Biot number of all the particles was 0.1. This implies that the Biot number increases as the paddle speed is reduced for all the particles.

This result shows that the evaluated preconditioner performed poorly at the selected speeds. However, it can be improved by further reducing the speed and increasing the retention time to obtain higher Biot number and hence higher mixing.

5. CONCLUSION

The preliminary evaluation of the machine in terms of mixing efficiency and throughput capacity indicates that it has high potential in improving the quality of feeds produced in Nigeria. Though, the mixing efficiency obtained from the test was low, further improvement on the operating conditions of the preconditioner will definitely increase the mixing efficiency of the system.

COMPETING INTERESTS

Authors have declared that no competing interests exist.

REFERENCES

1. Syama Dayal J, Ambasankar K, Kumraguruvasagam KP, Jannathulla R. Principles of feed formulations for shrimp/fish aquaculture. CIBA-TM Series. 2017;6:2. Accessed 1 December 2018. Available:https://www.researchgate.net/publication/319932207_PRINCIPLES_OF_FEED_FORMULATIONS_FOR_SHRIMPFI_SH_AQUACULTURE
2. Craig S, Helfrich LA. Understanding fish nutrition, feeds and feeding virginia cooperative extension, knowledge for the common wealth. Virginia Tech Publication USA. 2002;420-256.
3. Bolorunduro PI. Feed formulation and feeding practices in fish culture. National Agricultural Extension and Research Liaison Services, Ahmadu Bello University, Zaria. Nigeria. 2002;152(52).
4. Udo IU, Dickson BF. The Nigerian aqua-feed industry: potentials for commercial feed production. Nigerian Journal of Fisheries and Aquaculture. 2017;5(2):86-95. Accessed 1 December 2018. Available:<http://www.unimaid.edu.ng/Journals/Agriculture/NIJFAQ%20-Fisheries/NIJFAQ-5-2-17/86-95.pdf>
5. Aquaculture and inland fisheries project, annex II of the National special program for food security with the agriculture development program in all states and FCT Abuja, Nigeria. Inventory of Feed Producers in Nigeria. 2004;1-8.
6. Garcia SM, De Leiva MI, Grainger RJR. Review of the state of world fishery resources in 2003: marine fisheries. FAO Fisheries Technical Rome. 2005;457.
7. Ali YK, Aysun K, Hülya S, Çağdaş G, Yusuf Y, Tuğçe K. General evaluation of fish feed production in Turkey. Turkish Journal of Fisheries and Aquatic Sciences. 2017;17: 223-229. Accessed 1 December 2018. Available:https://www.researchgate.net/publication/316506442_General_evaluation_of_fish_feed_production_in_Turkey.
8. Woynarovich A, Bueno PB, Altan O, Jeney Z, Reantaso M, Xinhua Y, Van Anrooy R. Better practices for carp production in central and Eastern Europe, the Caucasus and central Asia. FAO Fisheries and Aquaculture Technical Paper. 2011;566.
9. Bailey LN, Hauck BW, Sevatson ES, Singer RE. Ready-to-eat breakfast cereal production. In: A. Turner (ed.) Food Technology International Europe, Sterling Publications International, London. 1995;127-132.
10. Vijayagopal P. Aquatic feed extrusion technology: An update. Fishing chimes. 2004;23:10-11. Accessed 27 July 2014. Available:http://eprints.cmfri.org.in/7281/1/277-FISHING_CHIMES_2004.pdf.
11. Tor AS. Fish physicochemical properties-impact on the fish feed extrusion process, phase transitions and physical pellet quality. AIT OSLO AS/University of Bergen. 2015;29. Accessed 1 December 2018. Available:<http://bora.uib.no/handle/1956/10080>.
12. Islam Sarkar MS, Simul Bhuyan MD. Identification and evaluation of fish feed ingredients in supporting the development of different feed mills in Bangladesh. American Journal of Zoology. 2018; 1(1): 1-6. Accessed 1 December 2018.

- Available:<http://www.sciencepublishinggroup.com/journal/paperinfo?journalid=657&doi=10.11648/j.ajz.20180101.11>
13. Khurmi RS, Gupta JK. A textbook of machine design (S. I Units). Eurasia publishing house (PVT) Ltd; 2005.
 14. Eugenio B. A closer look at preconditioning: mixing, residence time. 2004;55-56. Accessed 27 July 2014. Available:<http://pdf.gaalliance.org/pdf/GAA-Bortone-Dec04.pdf>.
 15. Urmas S, Martti T, Mart O, Lembit L, Vaino P. Optimization of process-control, size reduction and thermal treatment of animal by-products. Journal of Agriculture Food and Development. 2015;1:5-9.
 16. Tor S. Heat transfer in particulate foods. Department of Chemical Engineering, Lund University, Sweden; 2013.

© 2018 Olalusi et al.; This is an Open Access article distributed under the terms of the Creative Commons Attribution License (<http://creativecommons.org/licenses/by/4.0>), which permits unrestricted use, distribution, and reproduction in any medium, provided the original work is properly cited.

Peer-review history:
The peer review history for this paper can be accessed here:
<http://www.sciencedomain.org/review-history/28099>