



# **Comparison of Optimization of Exergy Efficiency of a Crude Distillation Unit Using Artificial Neural Network (ANN) and Response Surface Methods (RSM)**

**M. N. Braimah<sup>1\*</sup>**

<sup>1</sup>*Applied Thermodynamics and Process Design Unit, Department of Chemical Engineering, Obafemi Awolowo University, Ile-Ife, Osun State, Nigeria.*

## **Author's contribution**

*The sole author designed, analysed, interpreted and prepared the manuscript.*

## **Article Information**

DOI: 10.9734/JERR/2020/v14i317123

### Editor(s):

(1) Dr. Hamdy Mohy El-Din Afefy, Tanta University, Egypt.

### Reviewers:

(1) Malik El'houyouy Ahamadi, University of Comoros, Comoros.

(2) Hossein Asgharian, University of Isfahan, Iran.

Complete Peer review History: <http://www.sdiarticle4.com/review-history/58522>

**Original Research Article**

**Received 20 April 2020**

**Accepted 25 June 2020**

**Published 09 July 2020**

## **ABSTRACT**

The study carried out simulation of the Crude Distillation Unit (CDU) of the New Port Harcourt Refinery (NPHR) and performed exergy analysis of the Refinery. The Crude Distillation Unit (CDU) of the New Port Harcourt refinery was simulated using HYSYS (2006.5).

The Atmospheric Distillation Unit (ADU) which is the most inefficient unit and where major separation of the crude occurs was focused on. The simulation result was exported to Microsoft Excel Spreadsheet for exergy analysis. The ADU was optimized using statistical method and Artificial Neural Network. Box-Behnken model was applied to the sensitive operating variables that were identified. The statistical analysis of the RSM was carried out using Design Expert (6.0). Matlab software was used for the Artificial Neural Network. All the operating variables were combined to give the best optimum operating conditions.

Exergy efficiency of the ADU was 51.9% and 52.4% when chemical exergy was included and excluded respectively. The optimum operating conditions from statistical optimization (RSM) are 586.1 K for liquid inlet temperature, 595.5 kPa for liquid inlet pressure and condenser pressure of 124 kPa with exergy efficiency of 69.6% which is 33.0% increment as compared to the base case.

\*Corresponding author: Email: [mnerinoso1@gmail.com](mailto:mnerinoso1@gmail.com);

For the ANN optimization, the exergy efficiency of the ADU was estimated to be 70.6%. This gave an increase of 34.9% as compared to the base case. This study concluded that enormous improvement can be achieved both in design feasibility and improved efficiency if the feed operating parameters and other sensitive parameters are carefully chosen. Furthermore, ANN optimization gave better exergy efficiency of 70.6% than RSM optimization of 69.6%.

*Keywords: Artificial neural network; distillation; exergy efficiency; optimization; response surface methods.*

## **NOMENCLATURES**

$Q$  - external heat transferred (kJ/h)

$W_s$  – external work transferred (kJ/h)

$m_1$  - is the mass flow per unit time at inlet; the external work includes all forms of work whether it is shaft work as in the case of a pump or turbine, electrical work and so on (kg/h)

$h_1$  or  $H_1$  - inlet enthalpy (kJ/kg)

$m_2$  - is the mass flow per unit time at exit (kg/h)

$h^2$  or  $H_o$  - outlet enthalpy (kJ/kg)

$T$  – generic state temperature (K)

$T_o$  – reference temperature 298.15K

$P_o$  – reference pressure 101.325kPa

$P$  – generic state pressure (kPa)

$Ex_{ph}$  - physical exergy (kJ/kg)

$Ex_i$  - inlet physical exergy (kJ/kg)

$Ex_o$  - outlet physical exergy (kJ/kg)

$S_i$  - inlet entropy (kJ/kgK)

$S_o$  - outlet entropy (kJ/kgK)

$\Delta Ex_{phy}$  - change in physical exergy (kJ/kg)

$\Delta H$  - change in enthalpy (kJ/kg)

$\Delta S$  – change in entropy (kJ/kgK)

$x_{pci}$  - is the chemical exergy for pseudo-components

$x_i$  - is the chemical exergy component  $i$

$x_i$  - is the mole fraction of component  $i$

$R$  – is the universal gas constant 8.314kJ/kmol.K

$\beta_i$  - is the exergy correction factor as a function of its component C, H<sub>2</sub>, O<sub>2</sub>, S and N<sub>2</sub> mass fraction for the pseudo-components.

$\eta$  - Exergy efficiency

$I$  – Irreversibility (kJ/kg)

$i$  - is independent random variable

$b_o$  - is the mean of observations

$b_i$  - is unknown constant

$i$  - is the factor

$n$  - is the number of observations

$Y$ - is the predicted response

$x_i$  and  $x_j$  - coded variables

$b_o$  - is the offset term

$b_i$ ,  $b_{ii}$ , and  $b_{ij}$  - first-order, quadratic, and interaction effects, respectively

$i$  and  $j$  - index numbers for factor

$e_i$  - is the residual error

$Ex$  - is the exergy efficiency of the column

$LIN_{temp}$ , - is the liquid inlet temperature of the column

$LIN_{pres}$ , - is the liquid inlet pressure of the column

$CON_{temp}$  - is the condenser temperature

$CON_{pres}$  - is the condenser pressure

$PA1_{flow}$  - is the flow rate of the first pump around

$PA2_{flow}$  - is the flow rate of the second pump around

$PA3_{flow}$  - is the flow rate of the third pump around.

## 1. INTRODUCTION

Crude oil is a naturally occurring, smelly, yellow-to-black liquid consisting of a complex mixture of hydrocarbons of various molecular weights and other liquid organic compounds that are found in geologic formations beneath the Earth's surface. It can be refined to produce usable products such as gasoline, diesel and various forms of petrochemicals. Crude oil is a complex multi-component mixture which has to be separated into groups of compounds within relatively small range of boiling points or fractions and thus employ the use of a distillation process. Crude oil distillation is a very energy intensive process. The complexity is due to multiple products, side-strippers, heat exchangers and pump arounds, which turns the task of improving the energy efficiency of such a column into a complex task [1]. According to estimates about 40% of energy involved in refinery and other continuous chemical processes are consumed in distillation [2]. The energy demand of a distillation system is an increasingly important process performance factor, due to the increasing pressure to save energy; so energy savings in distillation processes would immediately cut the total energy consumption of the chemical industry. The main aim of conventional energy analysis of a crude oil distillation plant is to maximize the yield of the desired products. However, for economic and environmental reasons and the limited resources of energy, utilization of those energy resources needs to be maximized [3].

Exergy analysis, which may be considered as accounting of the use of useful energy and material resources, provides information on how effective a process takes place with respect to conservation of natural resources [4]. This is a significant improvement over the classical energy balance due to the ability of exergy to account for the 'quality' of energy entering and leaving the system. It is this ability that is exploited in analysis of process systems. Existing models have employed exergy analysis to determine where high energy wastages occur. From

previous studies on crude oil refinery, the Atmospheric Distillation Unit (ADU) which is a component of Crude Distillation Unit (CDU) has been identified as the unit with highest energy wastages [5].

Optimization can be defined as a tool used in decision making. Its purpose is to aid in the selection of better values for the decisions that can be made by a person in solving a problem. To formulate an optimization problem, one must resolve three issues. Firstly, model of the process that determines how the process performs in response to the decisions made. Secondly, evaluate the performance (an objective function) which is used to compare alternative solutions. Thirdly, to search for improvement [6]. To obtain useful information using computers, it, requires (1) critical analysis of the process or design, (2) insight about what the appropriate performance objectives are (i.e., what is to be accomplished), and (3) use of past experience, sometimes called engineering judgment. Engineers work to improve the initial design of equipment and strive to enhance the operation of that equipment once it is installed so as to realize the largest production, the greatest profit, the minimum cost, the least energy usage, and so on [7].

Response Surface Method (RSM) is a collection of mathematical and statistical technique used for modeling and analyzing a process in which a response of interest is influenced by several variables and the objective is to optimize this response [8]. RSM can either be linear model or non-linear model. Linear models are generally used in most studies to assess the dependent and independent factors. RSM have been used in the chemical and petroleum industries for optimization of processes for improved output [9-12]. In crude refinery, Wang et al. [13] showed that the response surface approach is more advantageous than single-factor analysis in the optimization of complex distillation columns, and the simulated results agreed well with the experimental data.

Artificial Neural network (ANN) are processing devices (algorithms or actual hardware) that are loosely modeled after the neuronal structure of the mammalian cerebral cortex but on much smaller scale. ANN combines artificial neurons in order to process information. The higher a weight of an artificial neuron is, the stronger the input which is multiplied by it will be. ANNs are used for engineering purposes, such as pattern recognition, forecasting, and data compression. ANN has been used in the petroleum industry for the prediction of crude oil viscosity for pipeline safety [14] and in the desalination process [15,16]. In the crude oil refinery process, ANN has been used to develop a controller for the distillation column where it was seen to perform optimally when compared with the installed distributed control system based on proportional integral and derivative algorithm with well over 95% correlation between the expected data and obtained data [17,18].

The present study hopes to compare the optimization of the operating variables of the atmospheric distillation unit of a crude oil refinery using ANN and RSM.

## 1.1 Process Description

The processing of crude oil is done in two stages in the distillation units of a refinery. We have the atmospheric distillation unit (ADU) and the vacuum distillation unit (VDU); the former is used for light fractions of the crude oil while the latter is employed in the heavier fractions of the crude oil. The products from these distillation units can either be the final or intermediate products. This research focused on the atmospheric distillation unit of crude distillation unit of the New Port Harcourt Refinery. The desalted raw crude is first preheated in a heater H1 and then flows to the pre-flash drum which separates it into liquid and partly vapour. The partly liquid crude is pumped P1 to the second heater H2 for preheating and flows to the crude charge heater H3. It then enters the flash zone of the atmospheric distillation unit (ADU). The partly vapourised crude from the pre-flash also enters the flash zone of the atmospheric distillation unit. The ADU operates above atmospheric pressure and is a long column that has 48 trays. The overhead vapours are condensed and produces Off Gas, Waste water and Naphtha. The bottom liquid and the liquid side cuts of the column contain light ends. Light ends are removed by injecting steam

and this process is called "Stripping". Stripping is done in both the main column and column for side products at the bottom for residue. In reality, three side cuts are drawn from trays 13, 26 and 36 respectively which are processed in separate strippers. The kerosene cut is fed into kerosene stripper (SS 1), from the 13<sup>th</sup> tray and vapour return to the main column at the 12<sup>th</sup> tray. The light diesel oil (LDO) cut is fed into the LDO stripper (SS 2) from the 26<sup>th</sup> tray and returns to the main column from the 25<sup>th</sup> tray. The Heavy Diesel Oil (HDO) cut is fed into the HDO stripper (SS 3) from the 36<sup>th</sup> tray and returns to the main column at the 35<sup>th</sup> tray. The products Kerosene, LDO and HDO are all sent to the storage facilities. There are three pump arounds in the process, the Pump Around 1 (PA1) is taken from tray 4 and returns to the main column at tray 1 while the second pump around PA2 is withdrawn at tray 15 and returns to the main column at tray 13. The 3<sup>rd</sup> pump around is withdrawn from tray 25 and returns back to the main column at tray 23 (Fig. 1).

## 1.2 Theory

### 1.2.1 Energy

The first law of thermodynamics states that energy is conserved, although it can be altered in form and transferred from one place to another, the total quantity remains constant. Thus, the first law of thermodynamics depends on the concept of energy; but, conversely, energy is an essential thermodynamic function because it allows the first law to be formulated.

### 1.2.2 Energy analysis

The energy analysis was performed using Equation 1 [19]

$$\sum_i \dot{E}_i + \dot{Q}_{cv} = \sum_e \dot{E}_e + \dot{W}_{cv} \quad (1)$$

Where  $i$  is inlet,  $e$  is the exit,  $\dot{E}$  is the energy rate (kJ/h),  $\dot{Q}$  is the heat transfer rate (kJ/h),  $\dot{W}$  is the work (kJ/h) and  $cv$  is the control volume.

### 1.2.3 Energy efficiency

The energy efficiency for each process unit was calculated using Equation 2 [19]

$$\text{Energy Efficiency} = \frac{\text{Energy out or products}}{\text{Energy in or feed}} \quad (2)$$

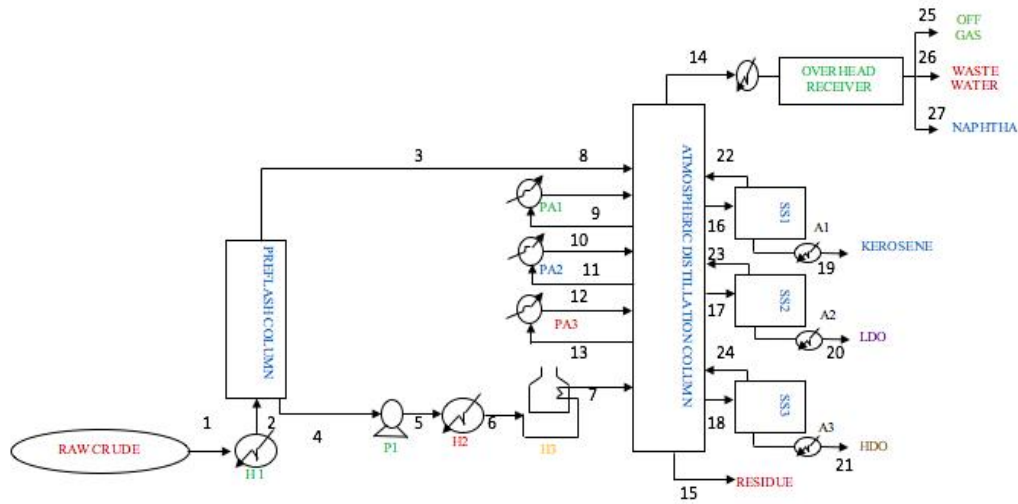

**Fig. 1. Schematic diagram of the CDU for New Port Harcourt refinery showing flow of crude oil to the final products**

### 1.2.4 Exergy

Exergy can be defined as the maximum amount of work which can be obtained as a process which is changed reversibly from the given state to a state of equilibrium with the environment, or the maximum work that can be obtained from any quantity of energy [20]. Exergy is divided into physical and chemical components [21].

### 1.2.5 Physical exergy

The physical exergy is the maximum useful work obtained by passing the unit of mass of a substance of the generic state (T, P) to the environmental (T<sub>o</sub>, P<sub>o</sub>) state through purely physical processes [22-24]. The reference system is defined with a reference temperature of 298.15K and a reference pressure of 101.325 kPa. Thus, if kinetic and potential energy are not taken into consideration, the specific physical exergy can be determined with the enthalpy and entropy values of the stream (characterized by its composition), both at the generic state and the environmental state temperatures and pressure. The Equation 3 can be used to illustrate how to calculate physical exergy assuming steady-state steady flow conditions and assuming both potential and kinetic energy are not contributing to the system.

$$Ex_{ph} = Ex_i - Ex_o = (H_i - H_o) - T_o(S_i - S_o) = \Delta Ex_{phy} = \Delta H - T_o \Delta S \quad (3)$$

### 1.2.6 Chemical exergy

Chemical exergy is equal to the maximum amount of work obtainable when the substance under consideration is brought from the environmental state to the reference state by processes involving heat transfer and exchange of substance only with the environment [25,26]. For a crude stream, the chemical exergy can be calculated from the standard molar chemical exergies of all identified components and pseudo-components as:

$$\Delta Ex_{ch} = \sum x_i \mathcal{E}_{x_{pci}} + \sum x_i \mathcal{E}_{x_i} + RT_o \sum x_i \ln x_i \quad (4)$$

Where  $\mathcal{E}_{x_{pci}}$  is the chemical exergy for pseudo-components

$\mathcal{E}_{x_i}$  is the chemical exergy component i  
 $x_i$  is the mole fraction of component i

For the identified components, the standard chemical exergy at reference temperature and pressure can be found in the literature, while for the pseudo-components (unidentified compounds of a crude oil) the chemical exergy for pseudo-components can be determined from heuristic empirical expression as a function of the elementary composition and their heating values [3,27,28]. This is calculated using Equation 5.

$$\mathcal{E}_{x_{pci}} = NHV_i \beta_i \quad (5)$$

$NHV_i$  is the net heating value of pseudo-component  $i$   
 $\beta_i$  is the exergy correction factor as a function of its component C, H<sub>2</sub>, O<sub>2</sub>, S and N<sub>2</sub> mass fraction for the pseudo-components.

$$\beta_i = 1.0401 + 0.1728 \frac{Z_{H_2}}{Z_C} + 0.0432 \frac{Z_{O_2}}{Z_C} + 0.219 \frac{Z_S}{Z_C} \left(1 - 2.0628 \frac{Z_{H_2}}{Z_C}\right) + 0.0428 \frac{Z_{N_2}}{Z_C} \quad (6)$$

### 1.2.7 Exergy efficiency

The exergy efficiency for each process unit was calculated using Equation 7.

$$\eta = \frac{\text{Exergy out or products}}{\text{Exergy in or feed}} \quad (7)$$

Irreversibility for each process unit was calculated using Equation 8.

$$I = \sum E_{X_{in}} - \sum E_{X_{out}} \quad (8)$$

### 1.3 Response Surface Method (RSM)

RSM is a collection of mathematical and statistical technique used for modeling and analyzing a process in which a response of interest is influenced by several variables and the objective is to optimize this response [8]. RSM can either be linear model or non-linear model. Linear models are generally used in most studies to assess the dependent and independent factors. In linear model, the behaviour of the dependent variable (response) can be expressed as equation 9 [29].

$$Y_i = b_o + \sum_{i=1}^n b_i x_{ii} + \mathcal{E}_i \quad (9)$$

Where  $\mathcal{E}_i$  is independent random variable,  $b_o$  is the mean of observations, and  $b_i$  is unknown constant,  $i$  is the factor and  $n$  is the number of observations.

In the current study, the non-linear model was used because they are important and necessary to consider an experimental design, which would allow one to fit the experimental data to a quadratic model [30]. The factorial design allows for experimentation of all main effects of the factors at any level and interactions between each pair of factor as well as all three ways interactions between each triplet of factors. Equation 10 is used to describe the non-linear model [8].

$$Y = b_o + \sum_{i=1}^n b_i x_i + \sum_{i=1}^n b_{ii} x_i^2 + \sum_{i=1}^{n-1} \sum_{j=i+1}^n b_{ij} x_i x_j + e_i \quad (10)$$

Where,  $Y$  is the predicted response;  $n$  is the number of factors;  $x_i$  and  $x_j$  are the coded variables;  $b_o$  is the offset term;  $b_i$ ,  $b_{ii}$ , and  $b_{ij}$  are the first-order, quadratic, and interaction effects, respectively;  $i$  and  $j$  are the index numbers for factor; and  $e_i$  is the residual error.

### 1.4 Optimizing the ADU Using Statistical Analysis

The response surface methodology (RSM) was used to evaluate the effects of sensitive operating variables from the parametric analysis in the ADU of the New Port-Harcourt refinery. The Box-Behnken design was used to screen significant factors among the three operating variables with respect to their effects on the operating condition of the crude distillation unit of the New Port-Harcourt refinery. The three factors are liquid inlet temperature (A), liquid inlet pressure (B) and condenser pressure. Each variable was represented at three levels i.e. low level (-1), medium level (0) and high level (+1). According to the Box-Behnken design developed by Design Expert Software (Version 7.1.6, Stat-Ease Inc, Minneapolis, MN, USA), seventeen runs of data was predicted by the software. A general second-order model that was employed is defined in Equation 11.

$$Y = b_o + \sum_{i=1}^n b_i x_i + \sum_{i=1}^n b_{ii} x_i^2 + \sum_{i=1}^{n-1} \sum_{j=i+1}^n b_{ij} x_i x_j + e_i \quad (11)$$

Where,  $Y$  is the predicted response;  $n$  is the number of factors;  $x_i$  and  $x_j$  are the coded variables;  $b_o$  is the offset term;  $b_i$ ,  $b_{ii}$ , and  $b_{ij}$  are the first-order, quadratic, and interaction effects, respectively;  $i$  and  $j$  are the index numbers for factor; and  $e_i$  is the residual error [8].

### 1.5 Artificial Neural Network (ANN)

ANN are processing devices (algorithms or actual hardware) that are loosely modeled after the neuronal structure of the mammalian cerebral cortex but on much smaller scale. ANN combines artificial neurons in order to process information. The higher a weight of an artificial neuron is, the stronger the input which is multiplied by it will be. Weights can also be negative, so we can say that the signal is inhibited by the negative weight.

## 1.6 Determining the Optimum Operating Conditions of the ADU using Artificial Neural Network (ANN)

ANN was used to determine the optimum operating conditions of the ADU, this was achieved by modeling it and simulating the model in computer software MATLAB. The ANN was designed and then trained with seventy percent of refinery data and thirty percent of the sample data. The optimization software was used to predict the flow rate of each of the crude oil final products from the column and also the exergy efficiency of the column. The relation between inputs and output of the process is given in Equation 12.

$$Ex = f(LI_{temp}, LI_{pres}, CON_{temp}, CON_{pres}, PA1_{flow}, PA2_{flow}, PA3_{flow}) \quad (12)$$

Where, Ex is the exergy efficiency of the column,  $LI_{temp}$  is the liquid inlet temperature of the column,  $LI_{pres}$  is the liquid inlet pressure of the column,  $CON_{temp}$  is the condenser temperature,  $CON_{pres}$  is the condenser pressure,  $PA1_{flow}$  is the flow rate of the first pump around,  $PA2_{flow}$  is the flow rate of the second pump around and  $PA3_{flow}$  is the flow rate of the third pump around.

To make the artificial neural network to be efficient, certain pre-processing was done on the inputs and the targets. The Newff function was used to automatically preprocess the inputs and targets and also post process the outputs, thus shortening the length of code required to achieve the process.

## 2. METHODOLOGY

### 2.1 Process Analysis Procedure

The process was simulated using HYSYS 2006.5 version and the data from the simulation was

exported to Microsoft Excel for exergy analysis. Parametric studies were performed by changing the operating variables (liquid inlet temperature, liquid inlet pressure, condenser temperature, condenser pressure, pump around flow rates 1, 2 and 3) to determine their effect on energy and exergy efficiencies. Data from the three most sensitive operating (liquid inlet temperature, liquid inlet pressure and condenser pressure) were chosen for optimization. The choice of these optimizing operating parameters did not affect the existing design of the Unit. Liquid inlet temperature, liquid inlet pressure and condenser pressure from the parametric analysis was extracted and exported to "Design Expert Software" to improve the performance of the Atmospheric Distillation Unit (ADU). Data from the parametric analysis was used in MATLAB for Artificial Neural Network (ANN) to get the optimum operating conditions of the ADU.

### 2.2 Simulation of the Crude Distillation Unit

The software (HYSYS 2006.5) was used for modeling and simulation of the crude distillation unit. The components that were chosen are from the refinery data which includes water, methane, ethane, propane, i-butane, n-butane, i-pentane and n-pentane. The fluid package chosen for this process is Peng-Robison. The crude oil was characterized using experimental assay which include API gravity, bulk crude properties, light end volume percent, TBP distillation and ASTM distillation. The assay data was fed into the data bank of HYSYS, the parameters are presented in Table 1.

The result of the characterization is a set of pseudo-components and a detailed chemical composition of the identified light end component and this is presented in Table 2.

Table 1. Bulk crude data

Bulk crude properties	Values
Api Gravity	34.87
Reid Vapor Pressure 38°Ckaf/cm <sup>2</sup>	0.3
BS and W% VOL	0.1
Pour Point °C	< 0
Ash Content %wt	0.00278
Conrandson Carbon Residue %wt	1
Salt Content PTB	1.04
Kinematic Viscosity at 38°C	3.66
Water Content %VOL	<0.05
Nickel ppm	0.022
Lead ppm	0.027

**Table 2. Light ends data**

Component	Percentage (%)
Propane	0.17
Isobutane	0.55
n-butane	1.02
Isopentane	0.33
n-pentane	0.14

**Table 3. Process stream data**

Streams	Temperature [K]	Pressure [kPa]	Molar Flow [kgmole/h]
Raw Crude	396.15	2210	4846.267
Hot Raw Crude	475.15	493.4323	4846.267
Preflash Vapour	475.15	493.4323	270.0916
Preflash liquid	475.15	493.4323	4576.176
Pumped Liquid	475.7579	1915.55	4576.176
Heated liquid 2	510.15	1719.4	4576.176
Liquid IN	626.15	395.5	4576.176
Steam 1	530.15	210	310.8503
Steam 2	581.15	202.33	58.28444
Steam 3	599.15	210.17	367.4695
Off Gas	334.4193	121	6.97E-03
Naphtha	334.4193	121	2265.652
Waste water	334.4193	121	721.9591
Residue	666.4272	210	768.2184
Kerosene	518.8966	179.8404	722.6215
LDO	560.821	191.0426	957.7515
HDO	561.3861	199.6596	146.6618

After the assay was calculated, the oil was cut and blended to produce hypothetical components that could be used in the simulation. This was done using the cut/blend tab on the oil manager environment. The cut was done using auto cut option which generates the hypothetical components based on the initial boiling point and the temperature ranges available. Once this was done, the oil was installed and made ready for use in simulation. The process stream parameters used in the simulation are as shown in Table 3.

### 3. RESULTS AND DISCUSSION

The Simulation diagram of the crude distillation unit is shown in Fig. 2 and the simulation diagram of the atmospheric distillation unit is shown in Fig. 3.

This is the main environment where the crude distillation unit was modeled using the operating and design data from the refinery. This was done to give a prototype of the actual refinery process. The simulation environment was entered and the raw crude temperature, pressure and mass flow rate values were imputed. After converging, the

simulation flow diagram of the CDU is as shown in Fig. 2, while the simulation diagram of the ADU is as shown in Fig. 3.

#### 3.1 Exergy Analysis of New Port Harcourt Refinery

Table 4 shows the summarized state parameters from the simulation and the streams that were considered in the analysis. Equations 3 and 4 was used to calculate exergy analysis, equation 7 was used in calculating efficiency while equation 8 was used to calculate irreversibility. The exergy efficiency result of the ADU is 51.9%. Every process has an element of irreversibility that makes it deviate from theoretical ideal performance and this is why exergy analysis of a process gives a better performance of a process than energy analysis [5,31].

The exergy analysis of the process system was calculated twice; i) with the chemical exergy term and ii) without the chemical exergy loss inherent to the separation process. This was done in other to show its contribution to the efficiency and irreversibility of the system. The irreversibility and exergy efficiencies when physical exergy alone



was considered are 39.96 MW and 52.4% respectively. When chemical exergy was included, the irreversibility and exergy efficiency were 40.21 MW and 51.9% respectively. The contribution of chemical exergy to the total exergy efficiency was 9.9% of the total exergy.

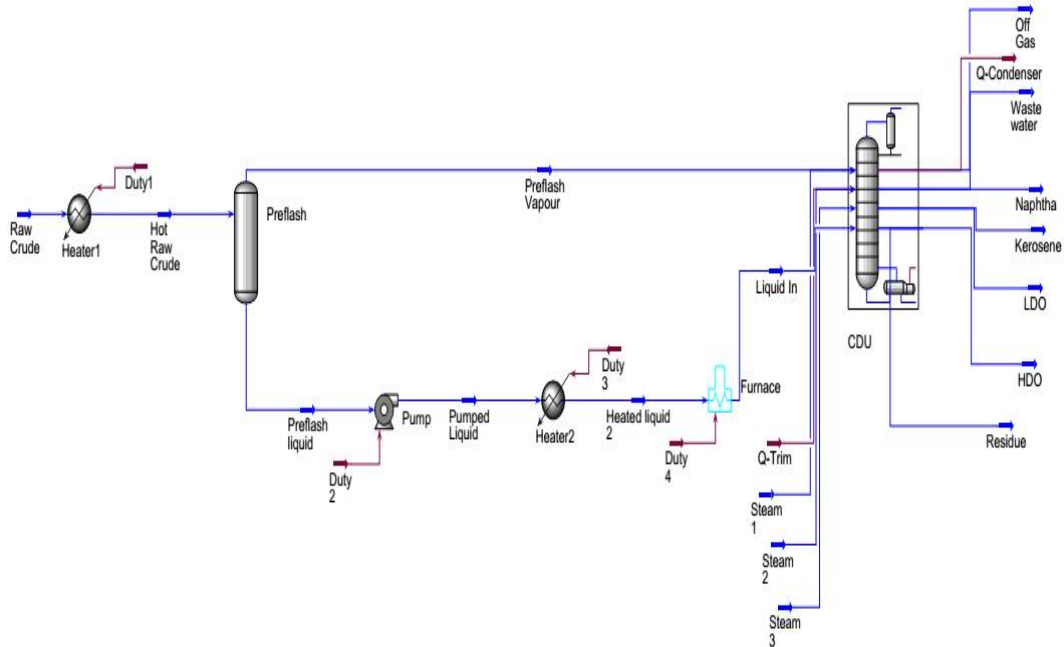

Fig. 2. Simulation diagram of the CDU for New Port Harcourt refinery [31]

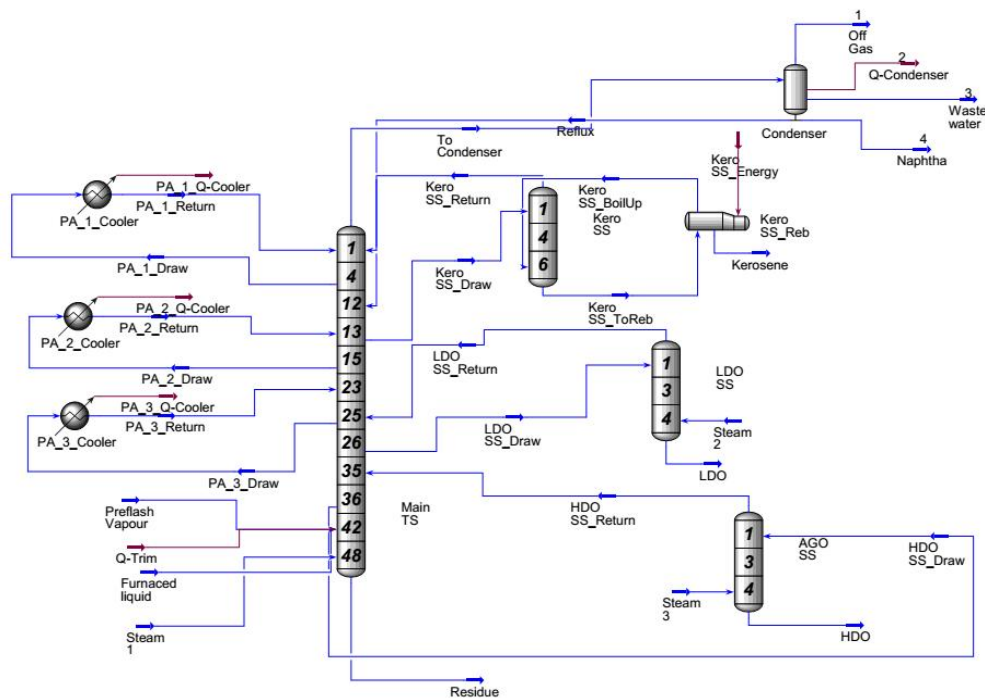

Fig. 3. Simulation diagram of the atmospheric distillation unit [31]

Table 4. State Parameters from the simulation [31]

Streams	Temperature [K]	Pressure [kPa]	Molar Flow [kgmole/h]	Molar Enthalpy [kJ/kgmole]	Molar Entropy [kJ/kgmole-K]	Physical Exergy (MW)	Total Exergy (MW)	Enthalpy (MW)
Raw Crude	396.15	2210	4846.267	-346137	254.2901	7.352417	7.3875456	48.35482
Hot Raw Crude	475.15	493.4323	4846.267	-311267	335.2233	21.8103	21.845424	95.29649
Preflash Vapour	475.15	493.4323	270.0916	-130255	183.9727	1.063672	1.289169	4.400336
Preflash liquid	475.15	493.4323	4576.176	-321951	344.1503	20.58496	20.60887	90.90949
Pumped Liquid	475.7579	1915.55	4576.176	-321467	344.3255	21.13343	21.157339	91.52435
Heated liquid 2	510.15	1719.4	4576.176	-304836	378.1802	29.44346	29.467369	112.6652
Liquid IN	626.15	395.5	4576.176	-220477	529.3757	79.37454	79.398448	219.8988
Steam 1	530.15	210	310.8503	-233896	187.3189	1.078273	1.0809121	4.518121
Steam 2	581.15	202.33	58.28444	-232048	190.9534	0.214548	0.2171865	0.877063
Steam 3	599.15	210.17	367.4695	-231392	191.7497	1.395352	1.3979904	5.596587
Off Gas	334.4193	121	6.97E-03	-148192	158.3043	2.71E-06	0.4290047	3.43E-05
Naphtha	334.4193	121	2265.652	-207746	51.03373	0.261046	0.3362186	4.534764
Waste water	334.4193	121	721.9591	-283398	62.635	0.031969	0.0346081	0.565984
Residue	666.4272	210	768.2184	-438986	1117.176	25.89994	25.899937	69.63923
Kerosene	518.8966	179.8404	722.6215	-269029	309.5246	4.49242	4.4924584	16.88083
LDO	560.821	191.0426	957.7515	-328185	496.6708	10.62238	10.622379	35.42203
HDO	561.3861	199.6596	146.6618	-418314	672.9251	2.044832	2.0448267	6.82418

In order to optimize the process plant efficiency, some operating parameters were varied and their effects on exergy efficiency of the ADU were determined. Three sensitive operating variables liquid inlet temperature, liquid inlet pressure and condenser pressure were chosen for optimization. The choice of the optimizing operating parameters did not affect the existing design of the Unit [31].

### 3.2 Response Surface Methodology Results

The Box-Behnken design was used to screen the sensitive operating variables in order to optimize the atmospheric distillation unit. The three sensitive operating variables liquid inlet temperature (A), liquid inlet pressure (B) and condenser pressure (C) and are represented at three levels i.e. low level (-1), medium level (0) and high level (+1). The liquid inlet temperatures at the three levels of low, medium and high are 586.1 K, 646.1 K and 706.1 K respectively. Liquid inlet pressure at the three levels of low, medium and high are 345.5 kPa, 470.5 kPa and 595.5 kPa respectively. For the condenser pressure the three levels of low, medium and high are 115kPa, 124kPa and 133kPa respectively.

For all combinations tested, exergy efficiency varied from 35.2% to 69.6% as shown in Table 5.

The highest exergy efficiency of 69.6% was calculated from the combination of liquid inlet

temperature of 586.1 K, liquid inlet pressure of 595.5 kPa and Condenser pressure of 124.0 kPa. The design expert software predicted the optimum operating conditions of the ADU when compared with the result of the parametric studies. From the Box–Behnken Design (RSM) studies, liquid inlet temperature of 586.1 K and liquid inlet pressure of 595.5 kPa gave the best exergy efficiency of 69.6%.

### 3.3 Optimization of the Atmospheric Distillation Unit

Three Dimensional (3D) response surface plots were generated as shown in Figs. 4 and 5. These plots show the predicted effects of process variables (liquid inlet temperature, liquid inlet pressure and condenser pressure) on responses (Exergy efficiency).

The 3D plots are the graphical representation of the regression equations in order to determine the optimum value of the variables within the design space [32].

The optimal values of the process variables were found to be combinations of AB and AC. For AB: liquid inlet pressure of 595.5 kPa and liquid inlet temperature of 586.1K gave the best optimum exergy efficiency of 69.5% as shown Fig. 4. For AC: liquid inlet temperature of 586.1 K and condenser pressure of 133 kPa gave exergy efficiency of 68% as shown Fig. 5.

**Table 5. The Box–behnken design of the variables with exergy efficiency as response [31]**

Run	A (°K)	B (kPa)	C(kPa)	Response (Exergy Efficiency (%))
1	646.10	470.50	124.00	47.54
2	647.10	345.50	133.00	47.03
3	706.10	470.50	133.00	35.59
4	706.10	595.50	124.00	35.74
5	706.10	345.50	124.00	35.54
6	646.10	345.50	115.00	46.55
<b>7</b>	<b>586.10</b>	<b>595.50</b>	<b>124.00</b>	<b>69.62</b>
8	586.10	345.50	124.00	66.08
9	646.10	470.50	124.00	47.54
10	586.10	470.50	115.00	67.36
11	706.10	470.50	115.00	35.22
12	646.10	595.50	133.00	48.46
13	646.10	470.50	124.00	47.57
14	586.10	470.50	133.00	68.06
15	646.10	470.50	124.00	47.54
16	646.10	595.50	115.00	47.95
17	646.10	470.50	124.00	47.54

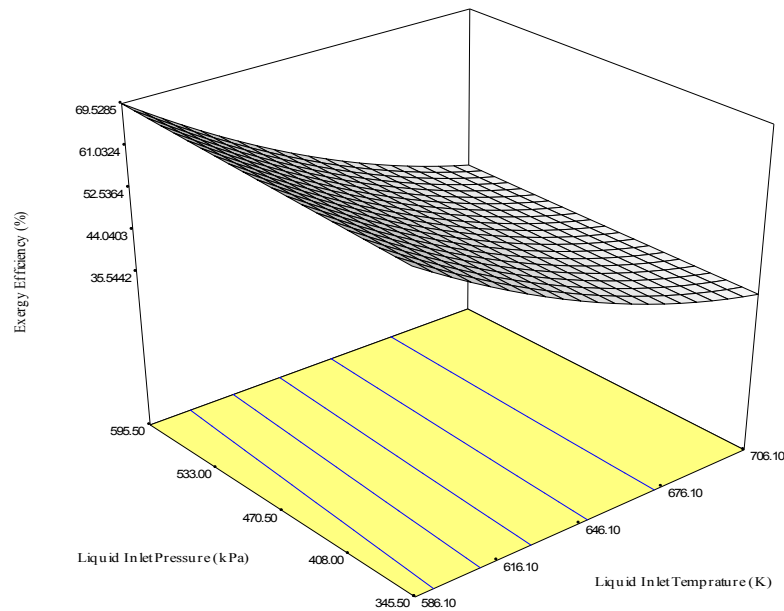

**Fig. 4. 3-D Response Surface Graph for AB (liquid inlet temperature and liquid inlet [31] pressure) combination**

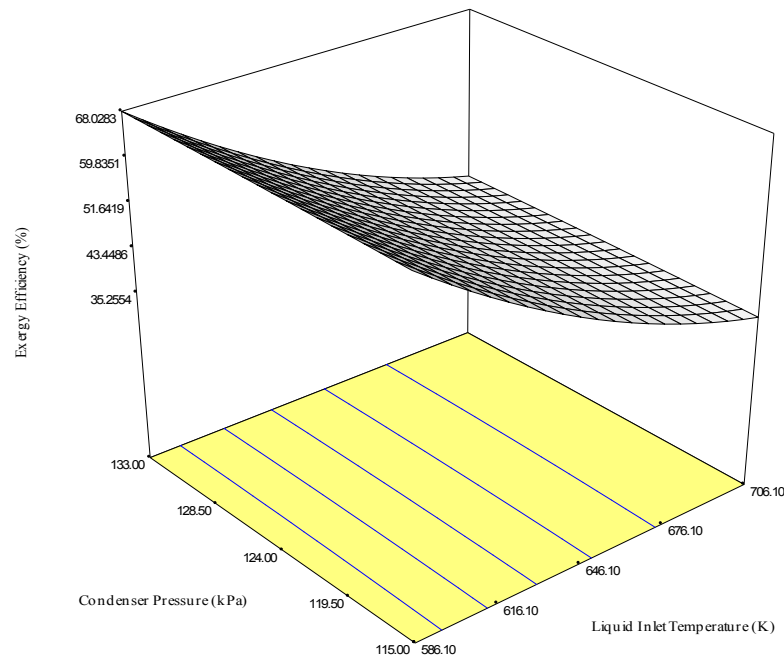

**Fig. 5. 3-D Response surface map for AC (liquid inlet temperature and condenser pressure) combination [31]**

The base case design of the ADU has exergy efficiency of 52.4%. These result shows that the optimal cases from the response surface methodology (RSM) above achieved an increase in exergy efficiency by 32.8% for the AB combination and 30.0% for the AC combination.

### 3.4 Artificial Neural Network Model

The ANN was trained to represent the knowledge data base of the ADU operating system using the ADU simulated runs from HYSYS. 2840 data set was used in training the ADU. 15% of the data

set was used to test the trained model. The relative error of the trained model and tested data was below  $1 \times 10^{-4}$  which shows that the ANN model was quite reliable in describing the input-output relationship of the ADU. The ANN model was able to adequately represent the complex process of the ADU due to non-linear characteristics of the ANN structure.

### 3.5 Optimum Operating Conditions

The optimization problem consists of an objective function (exergy efficiency) which was maximized with constraints from design and operating conditions. The operating variables liquid inlet temperature, liquid inlet pressure, condenser temperature, condenser pressure, pump-around flow rate 1, 2 and 3 with maximum and minimum values of 706.1 °K and 586.1 °K, 595.5 kPa and 345.5 kPa, 394.4 °K and 304.4 °K, 133 kPa and 115 kPa, 920.6 m<sup>3</sup>/h and 520.6 m<sup>3</sup>/h, 1007.9 m<sup>3</sup>/h and 607.9 m<sup>3</sup>/h and 678.8 m<sup>3</sup>/h and 278.8 m<sup>3</sup>/h respectively. The knowledge database of the neural network model was used in the optimization procedures. About 96 generations were made and the output with the least error was returned as optimum. The optimum operating variables liquid inlet temperature, liquid inlet pressure, condenser temperature, condenser pressure, pump-around flow rate 1, 2 and 3 are 586.1 °K, 410.0 kPa, 332.6 °K, 127.5 kPa, 696.3 m<sup>3</sup>/h, 799.0 m<sup>3</sup>/h, 585.8 m<sup>3</sup>/h respectively. The corresponding exergy efficiency for these combinations was 70.6%. This is a great improvement because the exergy efficiency increased by 34.9% as compared to the base case and 1.6% increment as at compared with the exergy efficiency obtained from statistical analysis. The ANN predicted the optimum operating conditions at which the ADU can operate with the least irreversibility and without changing the design and compromising the products quality. This can assist the operators in the decision making of running the column efficiently and thus reduce the environmental implications of unutilized energy.

### 4. CONCLUSIONS

The expert system of the atmospheric distillation unit was found to predict the optimal operating conditions of the atmospheric distillation unit for the objective function considered and thus minimizes the energy consumed in the unit. Both ANN and RSM were able to improve the efficiency of the atmospheric distillation unit of the refinery as compared with the base case, however, ANN optimization gave a better exergy

efficiency of 70.6% than RSM optimization of which gave exergy efficiency of 69.6%.

### ACKNOWLEDGEMENT

I want to acknowledge Prof AN Anozie and Dr OJ Odejobi for supervising the research work. I also want to appreciate the contribution of Dr RO Braimah in the final manuscript preparation.

### COMPETING INTERESTS

Author has declared that no competing interests exist.

### REFERENCES

1. Santana EI, Zemp RJ. Thermodynamic analysis of a crude oil fractionating process. Paper Presented at: 4<sup>th</sup> Mercosur Congress on Process Systems Engineering; 2001. Brazil.
2. Olujić Z, Fakhri F, De Rijke A, De Graauw J, Jansens PJ. Internal heat integration - the key to an energy conserving distillation column. *J. Chem. Tech. Biotech.* 2003;78: 241-47.
3. Al-Muslim H, Dincer I. Thermodynamic analysis of crude distillation systems. *Int J Energy Res.* 2005;29:637-53.
4. Sahin AZ. Importance of exergy analysis in industrial processes. Internal Seminar Lectures, Department of Mechanical Engineering, King Fahd University of Petroleum and Minerals, Saudi Arabia; 2004.
5. Osulale FN. Ph.D. thesis: Exergy and pinch analysis of crude oil distillation units of Warri and Kaduna Refineries. Ile-Ife: Obafemi Awolowo University; 2011.
6. Perry RH, Green DW. *Perry's Chemical Engineer's Handbook*: McGraw-Hill, 7<sup>th</sup> Ed; 1997.
7. Edgar TF, Himmelblau DM, Lasdon LS. *Optimization of chemical processes*. New York: McGraw-Hill; 1988.
8. Montgomery DC. *Design and analysis of experiments*, Fifth Ed. John Wiley and Sons, New York, USA; 2001.
9. Braimah MN, Anozie AN, Odejobi OJ. Utilization of Response Surface Methodology (RSM) in the optimization of crude oil refinery process, New Port-Harcourt Refinery, Nigeria. *Journal of Multidisciplinary Engineering, Science and Technology.* 2016;3(3):4361-69.
10. Kusmiyati, Amin NAS. Application of Central Composite Design (CCD) and

- Response Surface Methodology (RSM) in the catalytic conversion of 13 methane and ethylene into liquid fuel products. *Enzyme and Microbial Technnology*. 2004;20:257-52.
11. Drljo A, Liebmann B, Wukovits W, Friedl A. Predicting minimum energy conditions for a distillation column by design of experiments and process simulation. *Chem Eng T*. 2002;29:325-30.
  12. Bari N, Alam Z, Muyibi SA, Jamal P, Mamum AA. Statistical optimization of process parameters for the production of citric acid from oil palm empty fruits bunches. *Biotechnology*. 2010;9(4):554-63.
  13. Wang H, Cui X, Wang R, Li C. Response surface optimization of the operating parameters for a complex distillation column based on process simulation. *Energy Procedia*. 2012;16:571-78.
  14. Obanijesu EO, Omidiora EO. The artificial neural Network's prediction of crude oil viscosity for pipeline safety. *Petroleum Science and Technology*. 2009;27:412–26.
  15. Khayet M, Cojocar C. Artificial neural network model for desalination by sweeping gas membrane distillation. *Desalination*. 2013;308(2):102-10.
  16. Choi Y, Lee Y, Shin K, Park Y, Lee S. Analysis of long-term performance of full-scale reverse osmosis desalination plant using artificial neural network and tree model. *Environ Eng Res*. 2020;25(5):763-70.
  17. Tonnang HEZ, Olatunbosun A. Neural network controller for a crude oil distillation column. *ARNP Journal of Engineering and Applied Sciences*. 2010;5(6):74-82.
  18. Ahmed DF, Khalaf AH. Artificial neural networks controller for crude oil distillation column of Baiji Refinery. *J Chem Eng Process Technol*. 2016;7:272-81.
  19. Al-Muslim H, Dincer I, Zubair SM. Exergy analysis of single and two stage crude oil distillation unit. *ASME-Journal of Energy Resources Technology*. 2003;125(3):199-207.
  20. Kotas TJ. The exergy method of thermal plant analysis. Reprint Ed. Melbourne, Florida: Krieger; 1995.
  21. Kotas TJ. Concepts for Thermal Plant: Department of Mechanical Engineering, Queen Mary College, University of London. 1980;105-113.
  22. Aspelund A. An extendend pinch analysis and design procedure utilizing pressure base exergy for subambiente cooling. *App Therm Eng*. 2007;27:2633–49.
  23. Harvey S. Analysis of a reheat gas turbine cycle with chemical recuperation using aspen. *Energy Convers Manag*. 1997; 38(15-17):1671–79.
  24. Valero A. Exergy accounting: Capabilities and drawbacks. *Energy*. 2006;31:164-80.
  25. Hinderink AP, Kerhof FP, Lie AB, Swaan AJ, Van Der Kooi HJ. Exergy analysis with a flowsheeting simulator. Elsevier Science. 1996;4693-700.
  26. Cengel YA, Boles MA. Thermodynamics: An engineering approach. 4<sup>th</sup> Ed. New York: McGraw-Hill; 2004.
  27. Rivero R, Rendon C, Monroy L. The exergy of crude oil mixtures and petroleum fractions: Calculations and application. *Int J Applied Thermodynamics*. 1999;2(3): 115-23.
  28. Szargut J, Morris DR, Steward FR. Exergy analysis of thermal, chemical and metallurgical processes. New York: Hemisphere; 1988.
  29. Montgomery DC. Design and analysis of experiments, Third Ed. John Willy and Sons, New York, USA; 1991.
  30. Cochran WG, Cox GM. Experimental designs, Second Ed. John Wily and Sons, Singapore; 1957.
  31. Braimah MN. Exergy, exergoeconomic analyses and optimization of crude distillation unit of New Port Harcourt Refinery. PhD Thesis [Ile-Ife: Obafemi Awolowo University; 2015.
  32. Khuri AI, Cornell JA. Response surfaces: Designs and analyses. 2<sup>nd</sup> Ed. Marcel Dekker In., New York; 1996.

© 2020 Braimah; This is an Open Access article distributed under the terms of the Creative Commons Attribution License (<http://creativecommons.org/licenses/by/4.0>), which permits unrestricted use, distribution, and reproduction in any medium, provided the original work is properly cited.

*Peer-review history:*

*The peer review history for this paper can be accessed here:*  
<http://www.sdiarticle4.com/review-history/58522>